

## Basic Deck

This tip sheet provides easy-to-follow deck design, compliant with the 2021 International Residential Code (IRC) with Washington State Amendments.

## Typical Deck

This document provides building code information applicable to **prescriptive residential wood deck design**. You may need to hire a licensed architect or engineer to design a deck where any of the following conditions apply:

- The deck serves other than a one- or two-family dwelling
- The deck design includes more than one level
- The deck will support a hot tub, spa or other heavy object, including heavy deck covering (such as pavers)
- The walking surface is more than 14 feet above grade
- The deck ledger is attached to house overhangs, bay windows, bricks, stone, or concrete block
- The deck is bearing on ground with a slope greater than 1 foot horizontal for every 1 foot vertical
- The deck is self-supporting (not attached to an exterior wall)

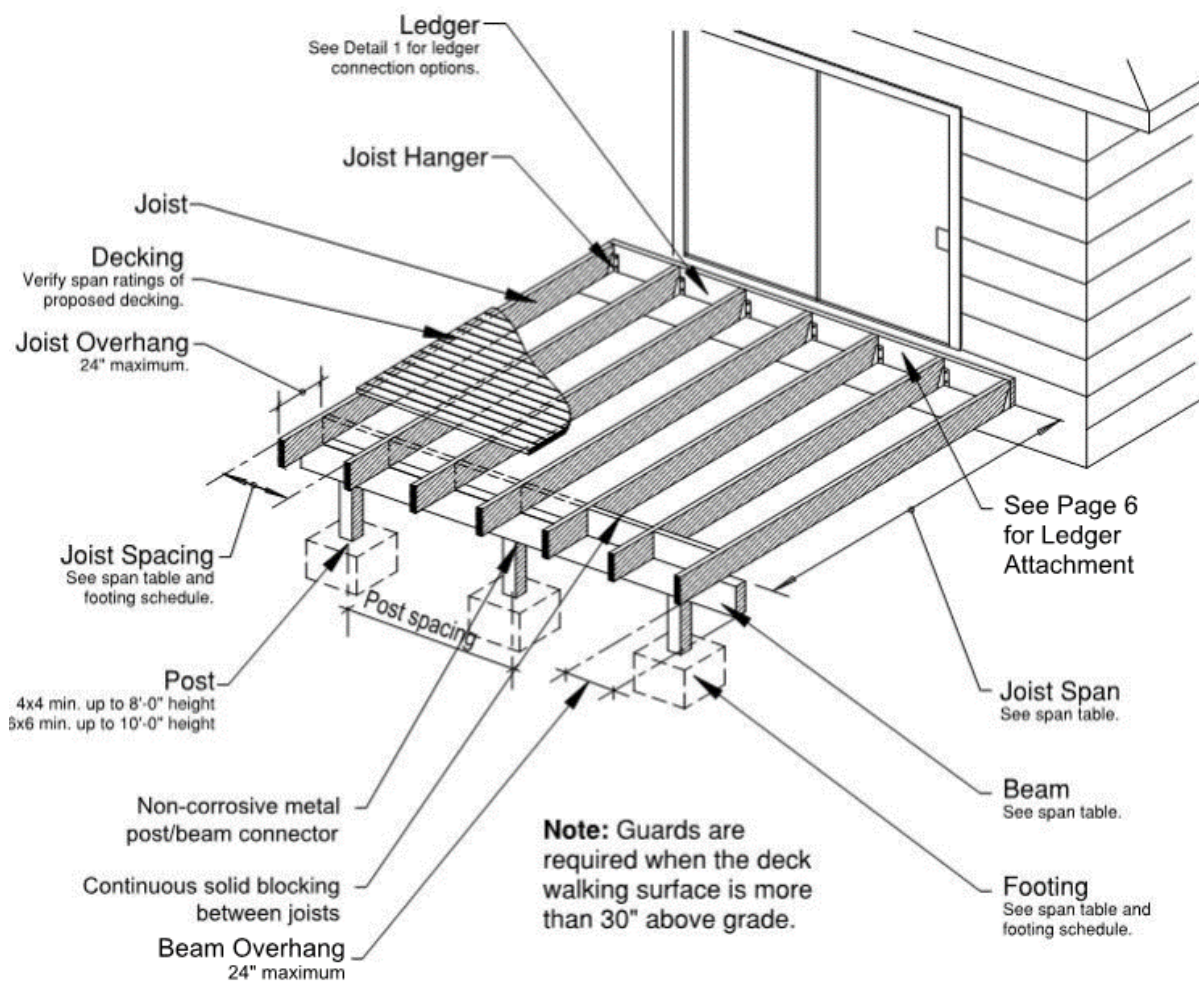

## Deck Construction Notes

- Design loading for decks is based on 60 pounds per square feet (PSF) live load, 10 PSF dead load, and 1500 PSF soil-bearing capacity.
- All wood must be pressure-treated or naturally resistant to decay (i.e. cedar, redwood, teak). Treat cuts, holes, and notches with end-cut solution. See Tip Sheet #11 for more information.
- Fasteners, hangers, nails, etc., must be stainless steel, hot-dipped galvanized, or as specifically required for the specified wood preservative used. The coating weights for zinc-coated fasteners to be in accordance with ASTM A 153. Provide documentation to your inspector.
- You may modify any components of this tip sheet using accepted engineering practices. **Any modifications must be reviewed prior to permit issuance.**
- All attachments must be per manufacturer's installation instructions.

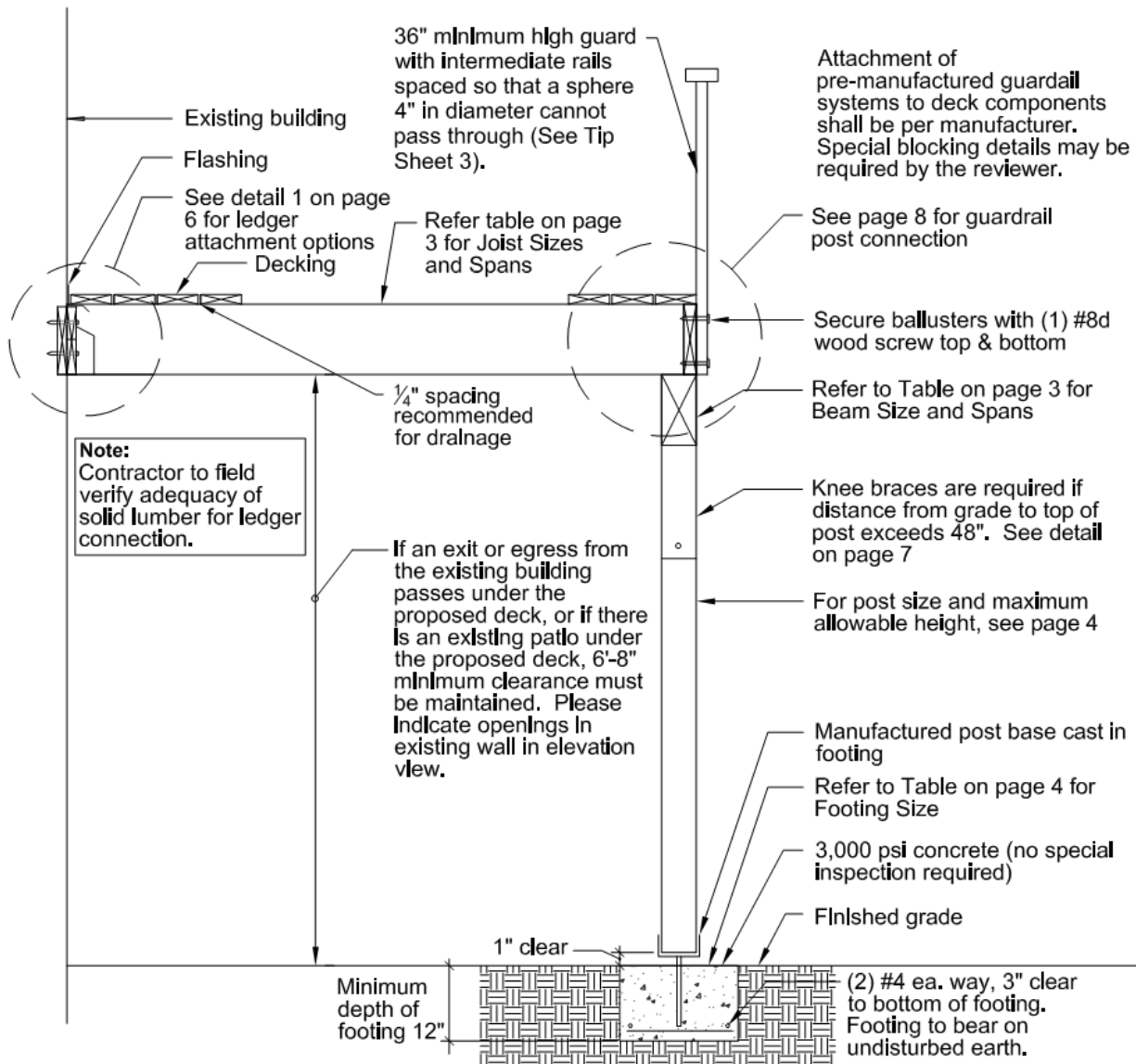

## Sizing of Structural Elements

When using the tables below, interpolation is allowed (but extrapolation is not allowed).

Maximum Deck Joist Span <sup>a, c</sup>											
Joist Size	Joist Spacing (inches) <sup>b</sup>			Joist Back Span (feet)							
	12	16	24	4	6	8	10	12	14	16	18
	Allowable Joist Span <sup>d</sup>			Maximum Cantilever (feet-inches) <sup>d</sup>							
2x6	7-11	7-1	5-9	1-0	1-6	NP	NP	NP	NP	NP	NP
2x8	10-5	9-5	7-8	1-0	1-6	2-0	2-1	NP	NP	NP	NP
2x10	13-3	11-6	9-5	1-0	1-6	2-0	2-6	2-8	NP	NP	NP
2x12	15-5	13-4	10-11	1-0	1-6	2-0	2-6	3-0	3-3	NP	NP

NP = Not Permitted

a. Includes Incising Factor.

b. When using composite decking, refer to manufacturer's installation instructions for maximum spacing of joists.

c. Spans based on Doug Fir-Larch, Hem Fir and Spruce-Pine-Fir, Number 2 grade, wet service factor.

d. For fire-retardant-treated wood (exterior grade), follow the manufacturer's span tables.

Minimum Beam Size							
Beam Size <sup>c, d, e, f</sup>	Deck Joist Span (feet)						
	6	8	10	12	14	16	18
	Maximum Beam Span <sup>a, b, d, f</sup> (feet-inches)						
4x6	5-2	4-6	4-0	3-5	3-1	2-10	2-7
4x8	6-11	6-0	5-3	4-7	4-1	3-8	3-5
4x10	8-5	7-4	6-6	5-10	5-2	4-9	4-5
4x12	9-10	8-6	7-7	6-11	6-4	5-9	5-4
6x6	6-6	5-7	5-0	4-7	4-2	3-9	3-5
6x8	8-8	7-6	6-8	6-1	5-6	5-0	4-7
6x10	10-7	9-2	8-2	7-6	6-11	6-4	5-10
6x12	12-4	10-8	9-7	8-9	8-1	7-7	7-1

a. Spans based on Doug Fir-Larch, Hem Fir and Spruce-Pine-Fir, Number 2 grade, wet service factor.

b. If 2x built up beams to make 4x or 6x beams, they shall be fastened with two rows of 10d (3-inch x 0.128-inch) nails minimum at 16 inches on center along each edge (R507.5).

c. Beam depth shall be equal to or greater than the depth of intersecting joist for a flush beam connection.

d. Beam cantilevers are limited to the adjacent beam's span divided by 4.

e. Includes incising factor.

f. For fire-retardant-treated wood (exterior grade), follow the manufacturer's span tables.

Post Size b, c	Maximum Deck Post Height							
	Tributary Area <sup>d</sup>							
	20	40	60	80	100	120	140	160
	Maximum Deck Post Height <sup>a, e</sup> (feet-inches)							
4x4	10-0	10-0	8-7	7-0	5-8	4-1	NP	NP
4x6	14-0	13-10	11-1	9-5	8-2	7-3	6-4	5-4
6x6	14-0	14-0	14-0	14-0	14-0	13-3	10-9	6-11
8x8	14-0	14-0	14-0	14-0	14-0	14-0	14-0	14-0

- a. Measured from the underside of the beam to top of footing.
- b. Based on Doug Fir, Hem Fir and Spruce-Pine-Fir, Number 2 grade, wet service factor.
- c. Includes incising factor.
- d. Area, in square feet, of deck surface supported by post and footing.
- e. For fire-retardant-treated wood (exterior grade), follow the manufacturer's height specifications.

Footing Size <sup>a</sup>			
Tributary Area <sup>b</sup>	Side of Square Footing (inches)	Diameter of Round Footing (inches)	Thickness (inches)
5	7	8	6
20	12	14	6
40	18	20	6
60	21	24	8
80	25	28	9
100	28	31	11
120	30	34	12
140	33	37	13
160	35	40	15

- a. Footing dimensions shall allow complete bearing of the post.
- b. Area, in square feet, of deck surface supported by post and footings.

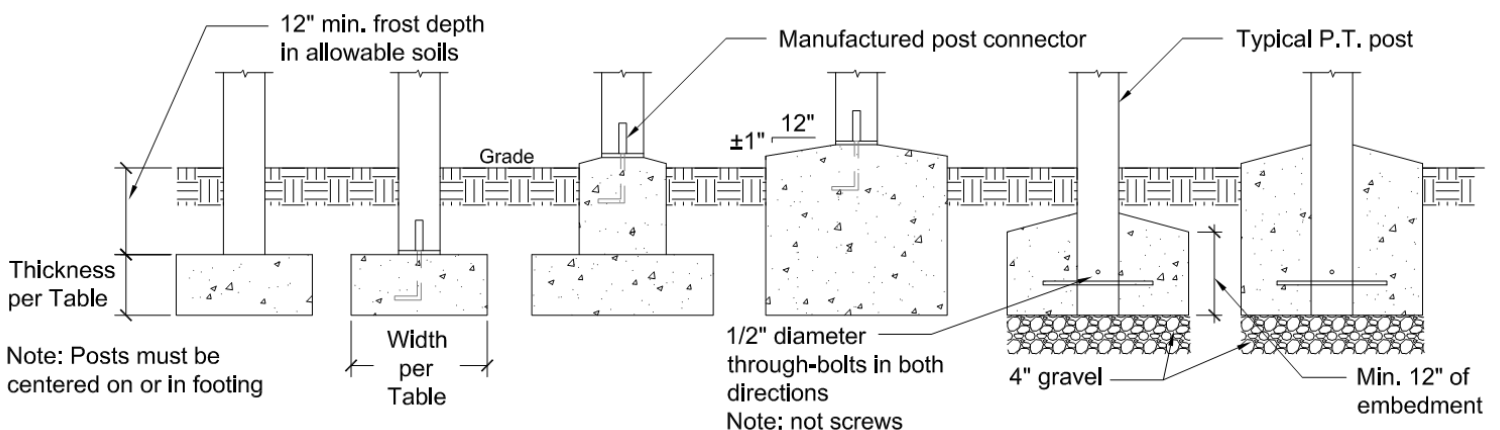

## Deck Ledger and Connections

Deck Ledger Connection to Band Joist			
Joist Span <sup>c</sup> (feet)	On-Center Spacing of Fasteners (inches)		
	1/2-inch diameter lag screw with 1/2-inch maximum sheathing <sup>b, c, e</sup>	1/2-inch diameter bolt with 1/2-inch maximum sheathing <sup>c</sup>	1/2-inch diameter bolt screw with 1-inch maximum sheathing <sup>d</sup>
6	22	36	35
8	16	31	26
10	13	25	21
12	11	20	17
14	9	17	15
16	8	15	13
18	7	13	11

- Ledgers shall be flashed in accordance with Section R703.4 to prevent water from contacting the house band joist.
- The tip of the lag screw shall fully extend beyond the inside face of the band joist.
- Sheathing shall be wood structural panel or solid sawn lumber.
- Sheathing shall be permitted to be wood structural panel, gypsum board, fiberboard, lumber, or foam sheathing. Up to 1/2-inch thickness of stacked washers shall be permitted to substitute for up to 1/2-inch of allowable sheathing thickness where combined with wood structural panel or lumber sheathing.
- For on-center spacing of specialized fasteners refer to the manufacturer's installation instructions.

## Placement of Lag Screws and Bolts in Ledgers and Band Joists

Minimum End and Edge Distance and Spacing Between Rows				
	Top Edge	Bottom Edge	Ends	Row Spacing
Ledger <sup>a</sup>	2 inches <sup>d</sup>	3/4 inch	2 inches <sup>b</sup>	1-5/8 inches <sup>b</sup>
Band joist <sup>c</sup>	3/4 inch	2 inches <sup>e</sup>	2 inches <sup>b</sup>	1-5/8 inches <sup>b</sup>

- Lag screws or bolts must be staggered from the top and bottom along the horizontal run. See figure below.
- Maximum 5 inches.
- For engineered rim joists, the manufacturer's recommendations govern.
- The minimum distance from the bottom row to the top edge of the ledger must be in accordance with figure below.
- 2 inches may be reduced to 3/4-inch when the band joist is directly supported by a mudsill, header, or by double top wall plates.

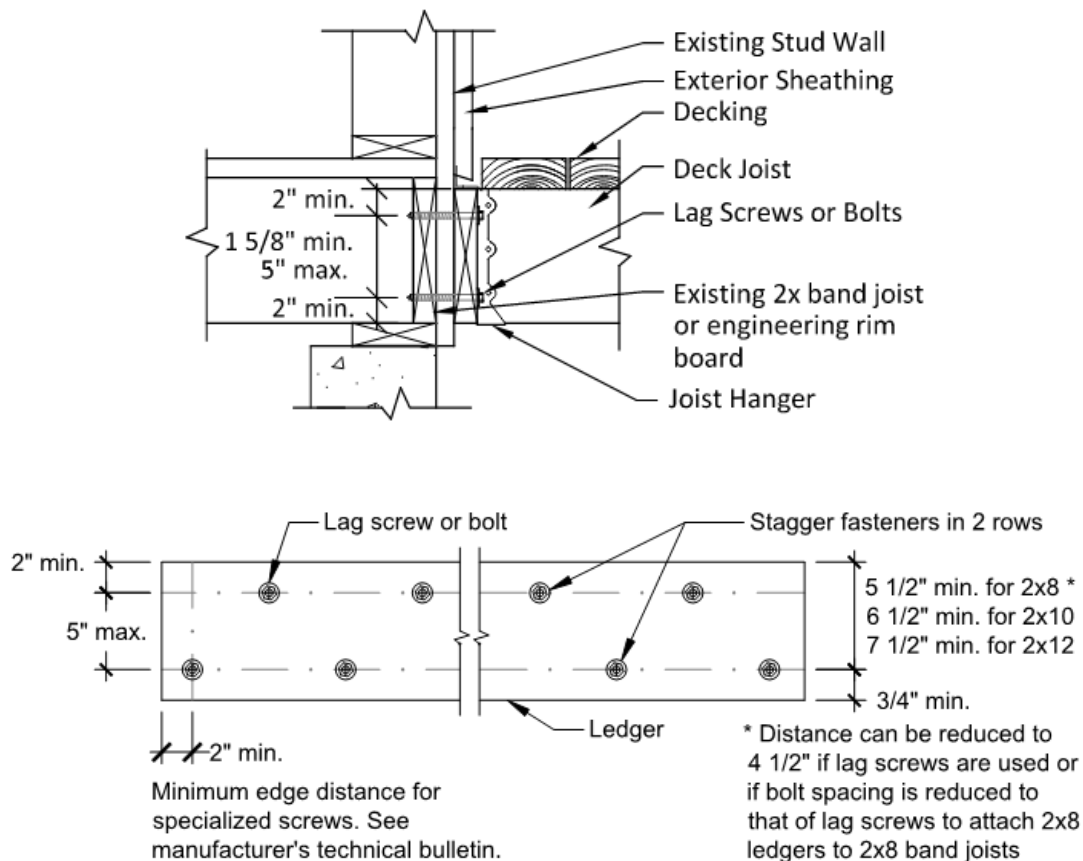

**Detail 1 – Ledger Attachment for Lateral Loads**

(Knee braces are required on posts greater than 4 feet in height.)

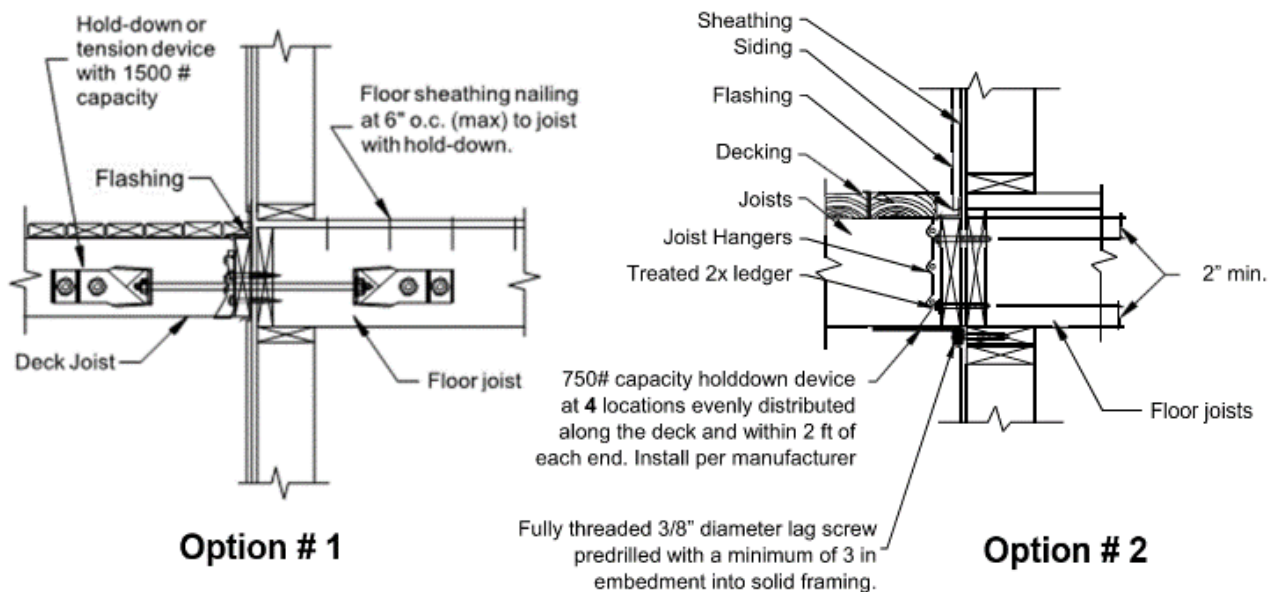

## Connections and Fasteners

All fasteners, nails, bolts, screws, and connectors must be corrosion resistant.

Type of Connection:	Notes:
Manufactured Connectors	Follow manufacturer's instructions
Post to Footing	Post base is required
Post to Footing (High Winds)	Consult with jurisdiction about additional uplift loads where wind exposure is greater than Risk Category B
Post to Beam	Connector is required
Ledger to House Framing	See information on Sheet 5 and Sheet 6
Joist to Beam or Girder	(3) 8d – Toe nailed
Blocking or Bridging to Joist	(2) 10d – Toe nailed at each end
Wooden Deck Boards	(2) 8d threaded nails <u>OR</u> (2) No. 8 screws
Composite Decking	Follow manufacturer's instructions

## Post to Beam Connection with Knee Brace

Knee braces are required on posts greater than 4 feet in height.

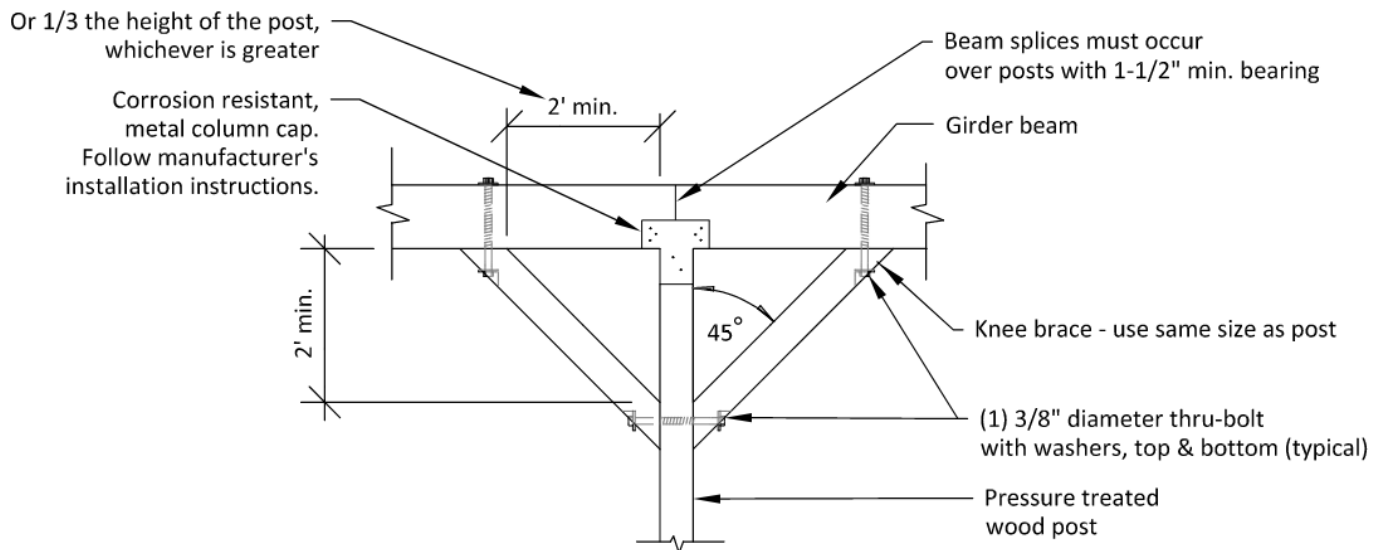

### Guards & Attachment

Guards are required when the deck is more than 30 inches above grade. See Tip Sheet #19 for safety glazing requirements for glass guards/infill panels.

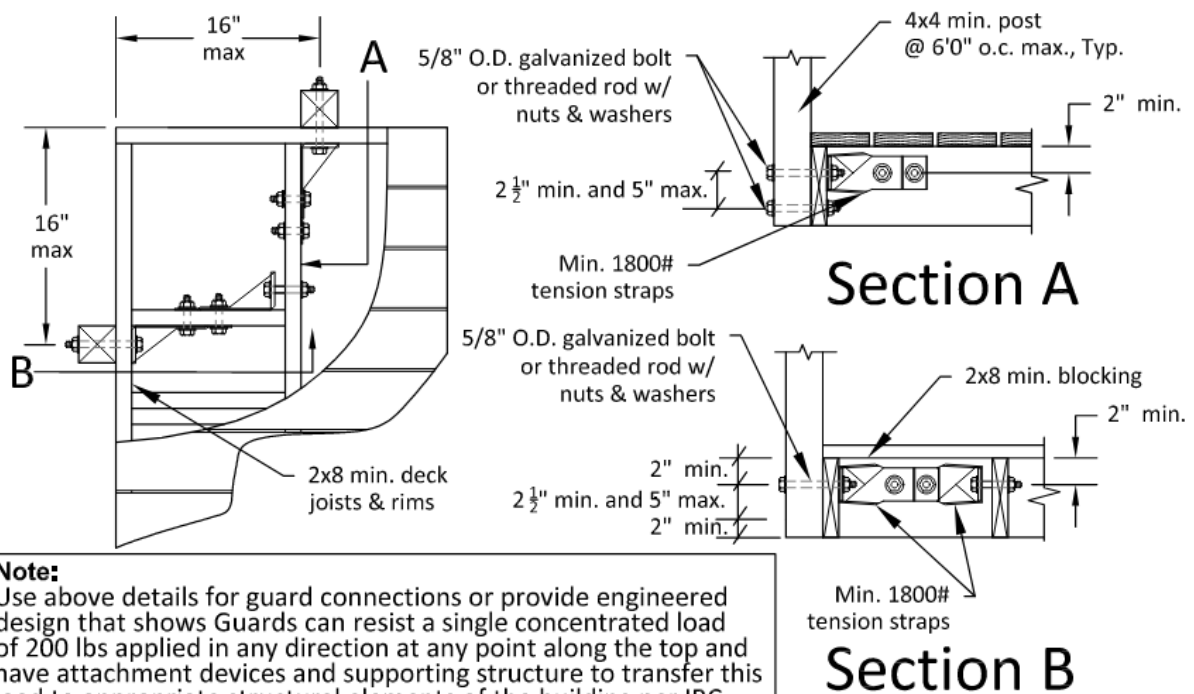
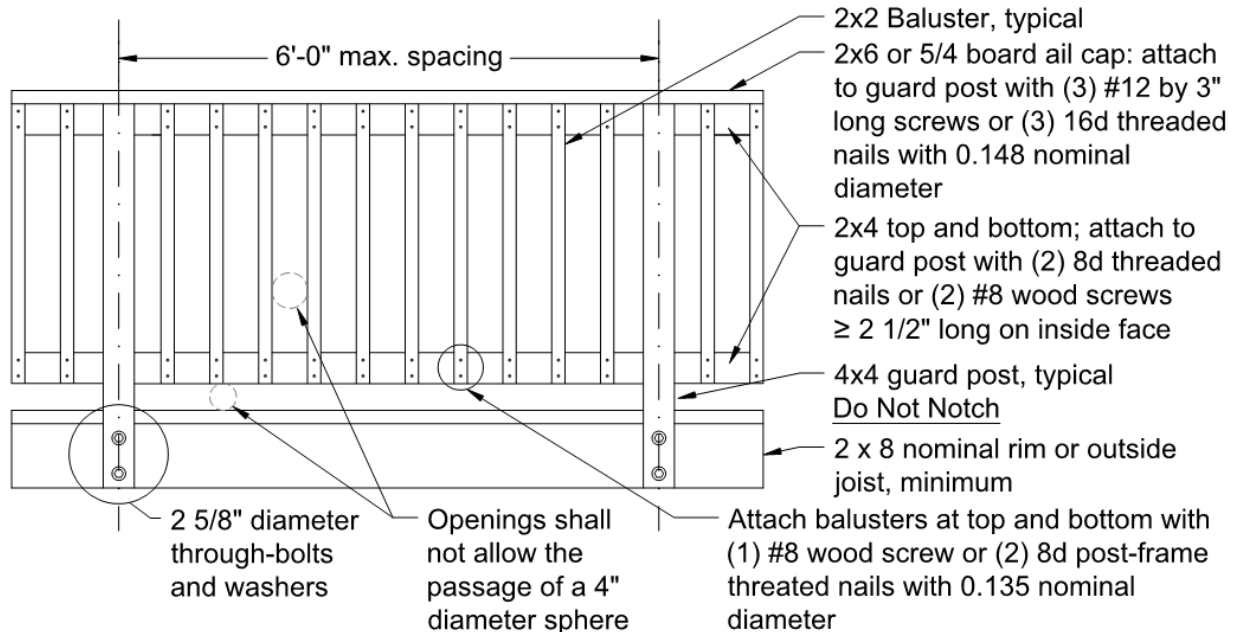

**Note:**  
Use above details for guard connections or provide engineered design that shows Guards can resist a single concentrated load of 200 lbs applied in any direction at any point along the top and have attachment devices and supporting structure to transfer this load to appropriate structural elements of the building per IBC sec 1607.9.1.1