



Department of Human Services

Doug Washburn
Director

KITSAP COUNTY
DEPARTMENT OF HUMAN
SERVICES

Sonya Miles
Deputy Director
Phone: 360-337-4839

Kesha Anderson - Evans
Office Supervisor
Phone: 360.337.7185 x 3530

Developmental Disabilities
Kelly Oneal, Coordinator
Phone: 360.337.4624

Behavioral Health
Jolene Kron, Administrator
Phone: 360.337.4832

Mental Health/Chemical
Dependency/Therapeutic Court
Hannah Shockley, Coordinator
Phone: 360.337.4827

1/10th Affordable Housing
Joel Warren, Coordinator
Email: jwarren@kitsap.gov

Pretrial Services
William Basler, Program
Specialist
Phone: 360.337.4457

Substance Abuse Prevention/
Treatment and Youth Services
Laura Hyde, Coordinator
Phone: 360.337.4879
Substance Abuse Prevention
Deanne Jackson, Prevention
Coalition Coordinator
Phone: 360.337.4878

Aging & Long-Term
Care/Senior Information &
Assistance
Givens Community Center
1026 Sidney Avenue, Suite 105
614 Division Street, MS-5
Port Orchard, WA 98366
Phone: 360.337.5700
1.800.562.6418
Fax: 360.337.5746
Stacey Smith, Administrator
Phone: 360.337.5624

Community Development
Block Grant
Norm Dicks Government
Center
345 6th Street, Suite 400
Bremerton, WA 98337
Fax: 360.337.4609
Bonnie Tufts, Coordinator
Phone: 360.337.4606

Housing and Homelessness
Carl Borg, Program Manager
Phone: 360.337.7286

Kitsap Recovery Center
Outpatient Services:
1026 Sidney Road
Port Orchard, WA 98366
Inpatient and Detox Services:
661 Taylor Street
Port Orchard, WA 98366
Fax: 360.377.7027
Keith Winfield, Clinical
Manager
Phone: 360.337.5640

Workforce Development
3120 NW Randall Way
Silverdale, WA 98383
William Dowling, Acting
Director
Phone: 253.370.1136.

Veterans Assistance
Richard Becker, Coordinator
Phone: 360.337.4811

Accessible Communities Advisory Committee

January 14, 2025
10 a.m. to 12 p.m.
Virtual Meeting via Zoom

AGENDA

Join the meeting

Dial by your location

1 253 215 8782 US (Tacoma)

Meeting ID: 860 7678 1072 | Passcode: 024088

1. CALL TO ORDER

2. INTRODUCTIONS

3. APPROVAL OF THE December 10, 2024, MINUTES* (attachment 1)

4. Christy DeGeus – Traffic Operations Manager, Kitsap County Public Works (ADA Transition)

5. UPDATES:

- a. Solstice Lantern Walk
- b. Kitsap Youth Human Rights Rally
- c. Dave Rasmussen – Emergency Management
- d. 2025 Work Plan*
- e. City of Poulsbo Accessible Tricycles
- f. Sea Discovery Center Accessible Door Project
- g. Portable Ramp Rentals

6. NEW BUSINESS:

- a. Week Without Driving 2025
- b. Bikes For All 2025
- c. ADA Transition Plan (attachment 2)

7. DELEGATION OF TASKS / MOVING FORWARD

8. ANNOUNCEMENTS

9. PUBLIC COMMENT

Please limit individual comments to **2 minutes**. Written comments may also be submitted to the Committee if this timeframe is insufficient.

10. UPCOMING MEETING: February 11, 2025, at 10 a.m.

11. ADJOURNMENT

* = Indicates action item



Accessible Communities Advisory Committee (ACAC)

10:00am - 12:00pm

Tuesday, December 10, 2024

1. **CALL TO ORDER:** Kris Colcock called the meeting to order at 10:07 a.m. via Zoom.

2. **INTRODUCTIONS:** Introductions were made, attendance was taken.

3. **APPROVAL OF THE November 12, 2024, MINUTES***

MOTION: Ranae Beeker moved to approve the November 12, 2024; minutes as presented. Marsha Cutting seconded. Motion carried.

4. **UPDATES:**

a. Putting the Social in Social Justice event

- Ranae was happy to share that this was a great networking event and that there was a great turnout and positive reaction. The ACAC was represented well, Nancy shared her excitement about being able to connect with people she hasn't seen since COVID.

b. Solstice Lantern Walk

- The Bloedel Reserve on Bainbridge Island is hosting guided lantern walks during the month of December. On December 17 Bloedel is offering an Accessible Solstice Stroll and Roll for people with disabilities that want to take part in a guided tour. This pilot program will give Bloedel an opportunity to learn how to better accommodate and design programs for people with disabilities. Each walk starts at 5pm and includes lantern use for each participant. The walks are around 1 ½ miles long and last approximately 1 hour. There are a limited number of spots as Bloedel caps the amount of people for each walk to 30 individuals. Rebecca created a flyer for this event and has shared it on various Kitsap County social media platforms. For additional information or to sign up for any of the offered solstice walks you can visit the [Bloedel Reserve](#) website.

c. City of Poulsbo Accessible Tricycles

- The City of Poulsbo Accessible Tricycles project involved purchasing two electric assist, adaptable tricycles for Kitsap County residential use. These tricycles will ultimately allow non accessible spaces to become accessible for community members who experience disabilities and/or limited mobility. The City of Poulsbo has been in the process of street testing the tricycles with a small focus group to better understand their motor and battery capacity. They will also be sending Justin a marketing plan by the end of the month with their plans on how they

intend to bring awareness to the community about the accessible tricycles' availability.

d. Sea Discovery Center Accessible Door Project

- The Sea Discovery Center accessible front door contract between Kitsap County and Western Washington University (WWU) is currently still in the county's routing process, but Justin is hopeful that this contract will be on the Board of County Commissioner's meeting agenda in January. Once construction begins on the accessible front door, it should only take a couple of days to complete.

5. NEW BUSINESS:

a. 2025 Advisory Group Work Plan

- Kris provided an overview of the 2025 Work Plan and suggested creating a work plan sub-committee to help finalize priorities. The sub-committee consisting of Ranae, Nancy, and Brent will share updates in January along with ACAC members voting on the finalized 2025 ACAC Work Plan.

b. Chair and Vice-Chair Nominations

- Kris will remain as Chair of the ACAC in 2025 and Brent will replace JR as Vice-Chair of the ACAC in 2025 after committee members voted.

6. DELEGATION OF TASKS / MOVING FORWARD

- Additional details on creating a Kitsap Youth Human Rights Rally sub-committee will take place during the January meeting.
- Preparation for Week Without Driving 2025 will be a topic going into the January meeting as a sub-committee will be created to ensure the ACAC is fully prepared.

7. ANNOUNCEMENTS

- Congratulations to both Kris for remaining as Chair and Brent for becoming Vice-Chair of the ACAC for 2025.

8. PUBLIC COMMENT

- None

9. UPCOMING MEETING: January 14, 2025, at 10 a.m. via Zoom.

10. ADJOURNMENT: The ACAC meeting adjourned at 11:45 a.m.

* = Indicates action items

ATTENDANCE		
MEMBERS	GUESTS	STAFF
<u>Present</u> Marsha Cutting Kris Colcock Angela Cox Brent Rotter Ranae Beeker James (JR) Kinnison Nancy Tietje <u>Absent</u> Jeff Vinecourt (unexcused) Molly Brooks (unexcused) Kat Woofter (excused) Amanda Gonzales (unexcused)	Erica Whares, Kitsap Public Health District Dani-Lou Gemmer, Central Kitsap High School Kaitlyn Moon, Community Member	Justin Wing Rebecca Pirtle

Kitsap County

Americans with Disabilities Act (ADA)

Transportation Facilities Transition Plan

Prepared by Transpo Group

December 2024

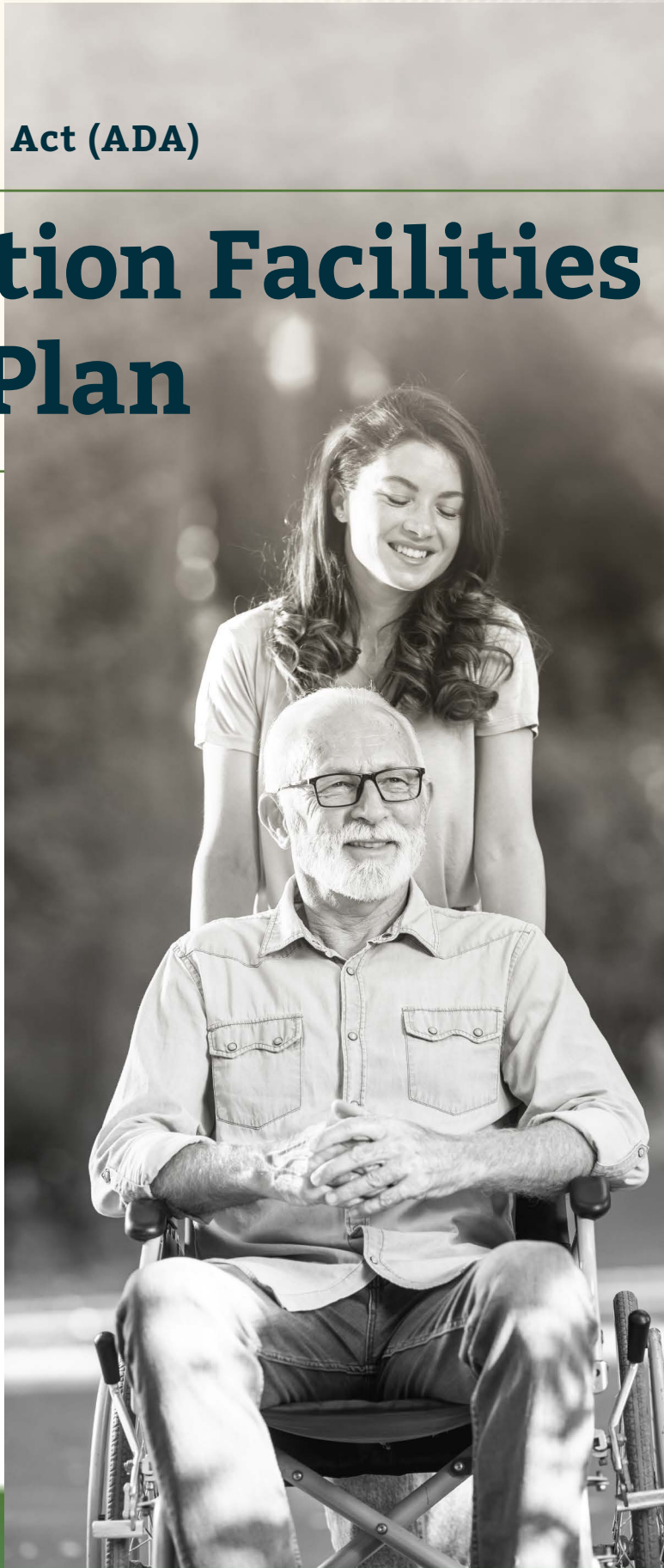



Kitsap County

619 Division Street
Port Orchard, WA 98366

360-337-5777
<https://www.kitsapgov.com/>

County Administration

Torie Brazitis, *County Administrator*
Joe Rutan, *County Engineer*
Andy Bradford, *GIS Analyst*

County Commissioner

Christine Rolfes, *District 1*
Oran Root, *District 2*
Katherine T. Walters, *District 3*

Additional copies of this document are available
online at: <https://www.kitsapada.com/>

For questions about the Kitsap County Americans with Disabilities Act (ADA) Transportation Facilities Transition Plan, or for access to an alternate format of this document, email the Kitsap County ADA Coordinator, Tim Perez, at Tperez@kitsap.gov, or call: 360-337-4675.

For those who are deaf or hard of hearing, the Washington State Relay can be contacted at 711 for assistance in making a request to the County.

Prepared By:

Transpo Group
12131 113th Ave NE, Ste. 203
Kirkland, WA 98034

Contents

Executive Summary	1
1 Introduction	2
1.1 Plan Requirement	2
1.2 Plan Structure	3
2 Self-Evaluation	4
2.1 Policy Review	4
2.2 Practices and Design Standards	5
2.3 Existing Pedestrian Facilities	7
3 Stakeholder Engagement	28
3.1 Engagement Methods	28
4 Pedestrian Barrier Removal Methods and Schedule	30
4.1 Barrier Removal Methods	30
4.2 Barrier Removal Plan and Schedule	32
5 Recommendations and Next Steps	52
5.1 Recommended Actions	52

Appendices

Appendix A: Standards Review Barrier Audit	57
Appendix B: Existing Data Inventory	82
Appendix C: Prioritization Criteria	88
Appendix D: Stakeholder Outreach	94
Appendix E: Planning Cost Estimate	109
Appendix F: Accessible Pedestrian Signal (APS) Policy Example	114
Appendix G: Grievance Procedure Example	116
Appendix H: Maximum Extent Feasible (MEF) Documentation Template	120
Appendix I: ADA Terminology	124

This page intentionally left blank

Executive Summary

This Americans with Disabilities Act Self-Evaluation and Transition Plan establishes Kitsap County's ongoing commitment to providing equitable access for all, including those with disabilities. In developing this plan, Kitsap County has undertaken a comprehensive evaluation of its facilities and policies related to the public right-of-way to determine what types of access barriers exist for individuals with disabilities. This plan will be used to help guide future planning and implementation of necessary accessibility improvements.

Both the Self-Evaluation and the Transition Plan are required elements of the federally mandated ADA Title II, which requires that government agencies provide equitable access to the programs and services that they offer. While the ADA applies to all aspects of government services, this document focuses on Kitsap County facilities within the public right-of-way. This includes attributes of sidewalks, curb ramps, crosswalks, and pedestrian push buttons, as these are the majority of the facility types inventoried by the County.

This document summarizes the Self-Evaluation, which includes an accessibility assessment of pedestrian facilities, as well as County practices and procedures which relate to them, such as curb ramp design standards. It also contains a Transition Plan, which identifies a schedule for the removal of barriers and identifies how the County will address requests for accommodation in a consistent manner.

The County's objective is to remove physical barriers within the public right-of-way using a combination of maintenance activities and a barrier removal program, in conjunction with capital project delivery, and developer improvements funding. The County is committed to removing these barriers, and in future years will implement projects to remove all barriers identified in this plan. In addition, the County is continually working towards maintaining ADA compliance for all future capital improvement projects, permitted development, and any other right-of-way construction projects.

1 Introduction

1.1 Plan Requirement

The Americans with Disabilities Act (ADA) was enacted on July 26, 1990, and provides comprehensive civil rights protections to persons with disabilities in the areas of employment, state and local government services, and access to public accommodations, transportation, and telecommunications.

Counties and other government agencies are required to have an ADA Self-Evaluation and Transition Plan when they grow beyond a threshold of 50 employees. While accessibility requirements extend to all public facilities, the scope of this plan is focused on accessibility within the public right-of-way.

Kitsap County has completed an inventory of its pedestrian facilities. This plan allows the County to prioritize the removal of barriers and update procedures as they relate to accessibility within the public right-of-way.

There are five titles, or parts, to the ADA, of which Title II is the most pertinent to travel within the public right-of-way and government owned buildings. Title II of the ADA requires public entities to make their existing “programs” accessible “except where to do so would result in a fundamental alteration in the nature of the program or an undue financial and administrative burden.” Public right-

of-way, public government buildings, and public parks all fall within the County’s programs.

This effort was initiated by Kitsap County to improve the accessibility of the County’s transportation facilities, and to satisfy the requirements of ADA Title II Part 35, Subpart D – Program Accessibility § 35.150 (d)(3) which states:

The plan shall, at a minimum:

- (i) Identify physical obstacles in the public entity’s facilities that limit the accessibility of its programs or activities to individuals with disabilities.
- (ii) Describe in detail the methods that will be used to make the facilities accessible.
- (iii) Specify the schedule for taking the steps necessary to achieve compliance with this section and, if the duration of the Transition Plan is longer than one year, identify steps that will be taken during each year.
- (iv) Indicate the official responsible for implementation of the plan.

To determine the physical obstacles in a public entity’s facility, the proper standards and guidance must be identified for each feature type.

The 2010 ADA Standards for Accessible Design (ADAS) is the document in which all Federal ADA

standards are collectively held. The 2010 ADAS and regulations from 28 CFR Part 36 replaced the 1991 ADA (ADA Accessibility Guidelines).

The Revised Draft Guidelines for Accessible Public Right-of-Way was published by the United States Access Board in 2005 to provide design guidance on establishing accessible facilities within the right-of-way. The United States Access Board's [Proposed Guidelines for Pedestrian Facilities in the Public Right-of-Way](#), or PROWAG, was published for comment in 2011. Upon consideration of the comments received, the final rule was then published in the Federal Register on August 8, 2023, as a revised set of guidelines for right-of-way pedestrian facilities. While the guidelines have not yet been adopted as federal standards, many public entities currently use the draft PROWAG as 'best practice' for features within the public right-of-way. This practice has been endorsed by the Federal Highway Administration (FHWA) and the US Access Board, and it is the standard to which the Washington State Department of Transportation adheres.

As data collection for this Transition Plan began prior to adoption of the 2023 PROWAG, the public right-of-way facilities evaluated under this plan were evaluated against 2011 PROWAG.

1.2 Plan Structure

The structure of this plan was organized to closely follow federal ADA Transition Plan requirements. This includes:

Chapter 1 – Introduction

Chapter 2 – Self-Evaluation Documents Self-Evaluation methods and findings for policies, practices, design standards, and pedestrian facilities that result in accessibility barriers.

Chapter 3 – Stakeholder Engagement Documents public engagement methods and findings.

Chapter 4 – Pedestrian Barrier Removal Methods and Schedule Provides an overview of existing barrier removal approaches employed by the County, describes barrier removal priorities, and develops a total planning level cost estimate for the removal of existing pedestrian barriers and an accompanying schedule.

Chapter 5 – Recommendations and Next Steps

Provides a set of recommendations to inform the implementation of this Transition Plan and ongoing removal of pedestrian barriers.

Several associated appendix items are included to supplement this plan.

2 Self-Evaluation

Title II of the Americans with Disabilities Act (ADA) requires that jurisdictions evaluate their services, programs, policies, and practices to determine whether they comply with the nondiscrimination requirements of the ADA.

This chapter describes the methods and findings of the Self-Evaluation. Section 2.1 provides an overview of ADA-related County policies. Next, Section 2.2 reviews County practices and design standards. Finally, Section 2.3 summarizes the Self-Evaluation's field data collection methods and findings regarding existing pedestrian facilities such as sidewalks and curb ramps.

2.1 Policy Review

Kitsap County primarily addresses pedestrian facilities in the County Road Design Standards, County Comprehensive Plan, Non-Motorized Facilities Plan, and Development Code.

The policies and standards were reviewed against the Access Board's Accessibility Guidelines for Pedestrian Facilities in the Public Right-of-Way, PROWAG 2023, and recommendations were provided to correct policy deficiencies as they relate to the ADA.

2.1.1 Method

These documents were reviewed for content that relates to existing ADA programs, policies, and practices.

2.1.2 Findings

Kitsap County's Comprehensive Plan, required by Washington State's Growth Management Act (GMA), articulates a series of goals, policies, objectives, actions, and standards that are intended to guide the day-to-day decisions by County Council and staff. The plan was adopted in 2016 and amended in 2020. The County has initiated an update of its Comprehensive Plan as part of the 2024 GMA periodic update cycle. Comprehensive Plan elements include land use, housing, capital facilities, utilities, transportation, economic development, parks and recreation, environmental protection, and shoreline.

Goals and policies connected to transportation, specifically pedestrian facilities, within the 2016 adopted Comprehensive Plan generally include the following:

Multi-modal transportation: Provide a safe, balanced and efficient multimodal transportation system that adequately serves the future growth and development of the county.

- Develop a system of non-motorized transportation facilities that are constructed primarily within the right-of-way of existing and proposed public streets or roads.
- Provide opportunities for people to make choices among alternative modes of travel with an emphasis on moving people rather than vehicles and maximize opportunities for non-motorized travel.
- Provide a safe and reliable multi-modal transportation system for people of all ages and abilities.

2.2 Practices and Design Standards

Practices and municipal design guidelines that incorporate ADA standards are essential to ensure that newly constructed or upgraded pedestrian facilities are compliant with ADA Title II and Section 504 requirements and therefore reduce the number of accessibility barriers throughout the county.

This section summarizes a review of the [Kitsap County Road Standard, June 2020 \(KCRS\)](#), [Kitsap County Code \(KCC\)](#), and the [Kitsap County Comprehensive Plan](#) to identify any barriers to accessible design. The review was conducted in March 2024. For greater detail on the practices and standards review, see Appendix A for a barrier audit memo.

2.2.1 Method

The [Kitsap County Road Standard](#), Kitsap County Comprehensive Plan, and [KCC](#) were reviewed for compliance with ADA guidelines found in the 2023 [Proposed Guidelines for Pedestrian Facilities in the Public Right-of-Way](#), or PROWAG.

2.2.2 Findings

The Kitsap County Road Standard and KCC maintain adopted design standard plans and guidelines for sidewalks, shared use pathways, curb ramps, on-street parking spaces and driveways, Figure 2.1 shows the web pages where the road standards and municipal code can be accessed.

The County's design standards and code are limited to guidance for sidewalks, shared use pathways, curb ramps, pedestrian signals, and driveways, which represent a portion of the specific design elements associated with ADA compliance. This review recommends changes to current Kitsap County standards to achieve ADA compliance and improve clarity. Recommendations to the County standards are intended to improve clarity, increase consistency across figures, and provide a greater level of detail for design elements that have not yet been addressed.

The County's standards and code do not address crosswalks, transit stops, wheelchair ramps, or staircases. It is recommended for many of these areas that the County may modify the Kitsap County KCRS or KCC to include sections detailing the recommended design requirements that are currently missing, as noted in the barrier audit memo included in Appendix A.

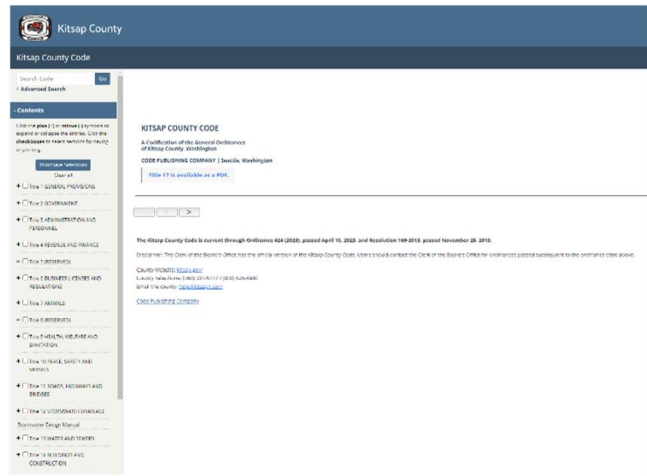
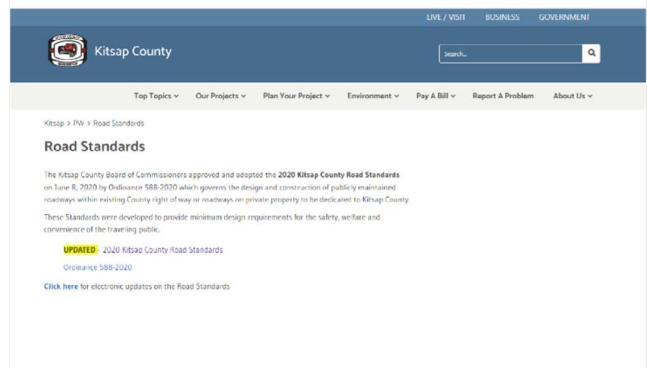

Figure 2.1 Kitsap County Road Standards Webpage and Kitsap County Code Webpage



Push Buttons



Curb Ramps



Sidewalks



Hazards

Figure 2.2 Examples of Inventoried Facilities

2.3 Existing Pedestrian Facilities

The Self-Evaluation inventoried access barriers associated with existing pedestrian facilities, including curb ramps, sidewalks, crosswalks, and pedestrian push buttons, as required by ADA Title II Part 35, Subpart D – Program Accessibility § 35.150 (d)(3). Each facility and its associated barriers were field inventoried and cataloged within the project’s geospatial (GIS) database. Curb ramp, push button, and sidewalk field data were collected by Transpo Group and Kitsap County staff between mid-September 2023 and July 2024.

Many existing pedestrian features in the Kitsap County right-of-way contain barriers and require improvements to meet current ADA standards. It is important to note that many of these facilities were constructed before the adoption of current ADA standards and likely met applicable state and federal standards at the time of construction. Additionally, it is important to note that ADA regulations require facilities to be made accessible to “the maximum extent feasible,” (MEF) in “circumstances when the unique characteristics of terrain prevent the incorporation of accessibility features” (U.S. Department of Justice, 28 CFR § 35.151). These circumstances are often the result of adjacent topography or otherwise constrained locations, which are common to the Kitsap County road system. This plan’s Self-Evaluation examined whether facilities were compliant with current ADA design requirements;

it did not examine whether non-compliant facilities were built to the maximum extent feasible or, with the exception of missing curb ramps, perform a gap assessment of facilities that have not been built.

Additional detail regarding the Self-Evaluation’s findings for curb ramps, sidewalks, and pedestrian push buttons is provided in the following sections.

2.3.1 Method

A Self-Evaluation of priority facilities within the public right-of-way was conducted by Kitsap County staff and by Transpo Group on behalf of the County. The data collection included pedestrian push buttons, sidewalks, driveways, hazards, crosswalks, and curb ramps.

The physical inventory of pedestrian facilities, as shown in Figure 2.2, included:

- 1,685 sidewalks, totaling approximately 98.8 miles
- 2,693 curb ramps (including 453 missing ramps)
- 334 pedestrian signal push buttons
- 394 crosswalks
- 1,637 non-compliant driveways
- 9,061 hazards

Inventory maps of collected pedestrian features can be found in Appendix B.

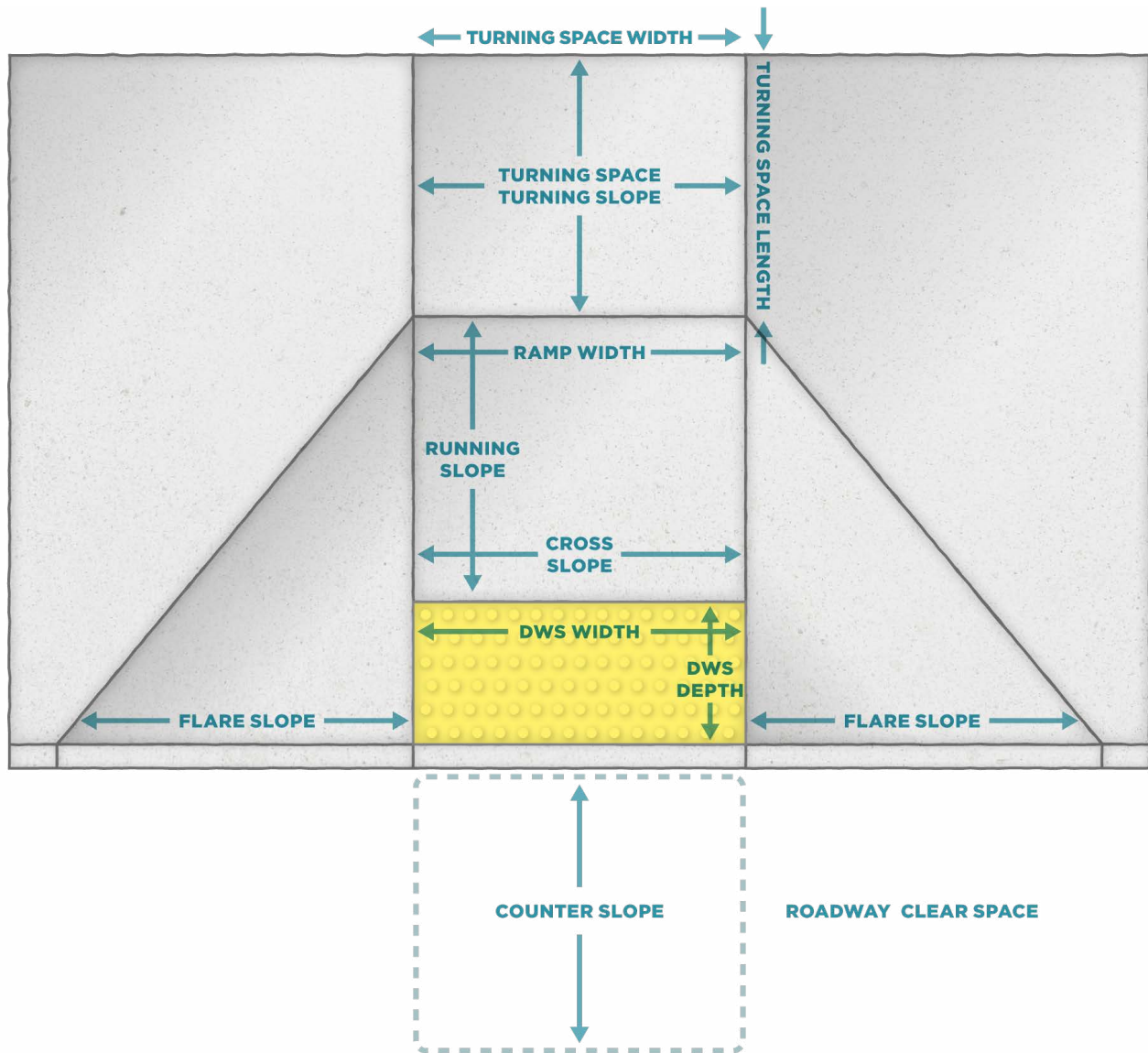

Figure 2.3 Perpendicular Curb Ramp Attributes

Curb Ramps

Field data were collected for curb ramps by Transpo Group and Kitsap County staff. The field data were then evaluated for their compliance with ADA standards. Figure 2.3 and Figure 2.4 show the typical major components of two common types of curb ramps, perpendicular and parallel.

Data collected for each curb ramp were reviewed for compliance, then scored based on the degree to which any barriers impeded

accessibility. Curb ramps were scored using a scale of 0-30 and categorized as follows:

- 0: Compliant.
- 1-29: Minor Compliance Issue.
- 30: Significant Compliance Issue.

These scores are referred to as the Accessibility Index Score (AIS). Curb ramps that had running slopes that were too steep received a score of 30 and were considered non-compliant. Curb ramps that had cross slopes slightly above the compliant threshold received a score of 20 while steeper cross slopes received a 30.

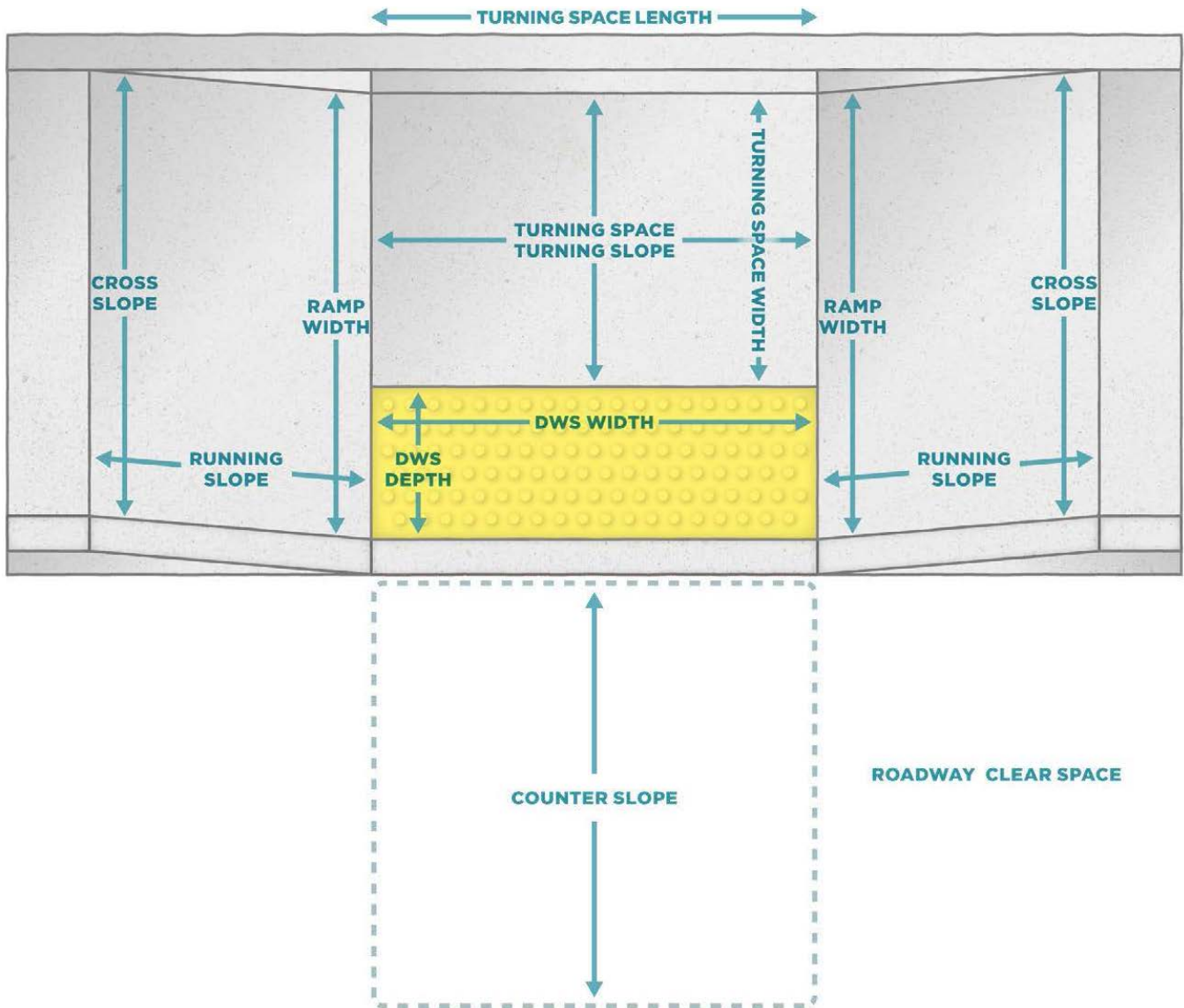

Figure 2.4 Parallel Curb Ramp Attributes

Other criteria relating to turning space, flare slopes, detectable warning surfaces (DWS), obstructions, and condition were weighted lower, but could cumulatively reach the threshold for non-compliance.

To maximize efficiency during data collection, an optimization process was used to collect curb ramp data. If the width, running slope, or cross slope was found to be non-compliant, it is assumed that the remedy to correct the accessibility barrier would be full replacement. Because of this, if the accessibility criteria listed above were found to be

out of compliance, data collectors would cease collecting and move on to the next feature.

The Accessibility Index Score represents the first component of a two-part scoring system. The relative importance of features, defined through community engagement, is considered in the second component of scoring and referred to as the Location Index Score. The two scores are then summed to provide prioritized scores for each facility feature as a Combined Index Score. Scoring and compliance criteria for all features are discussed in more detail in Section 4.2.1 and in Appendix C.

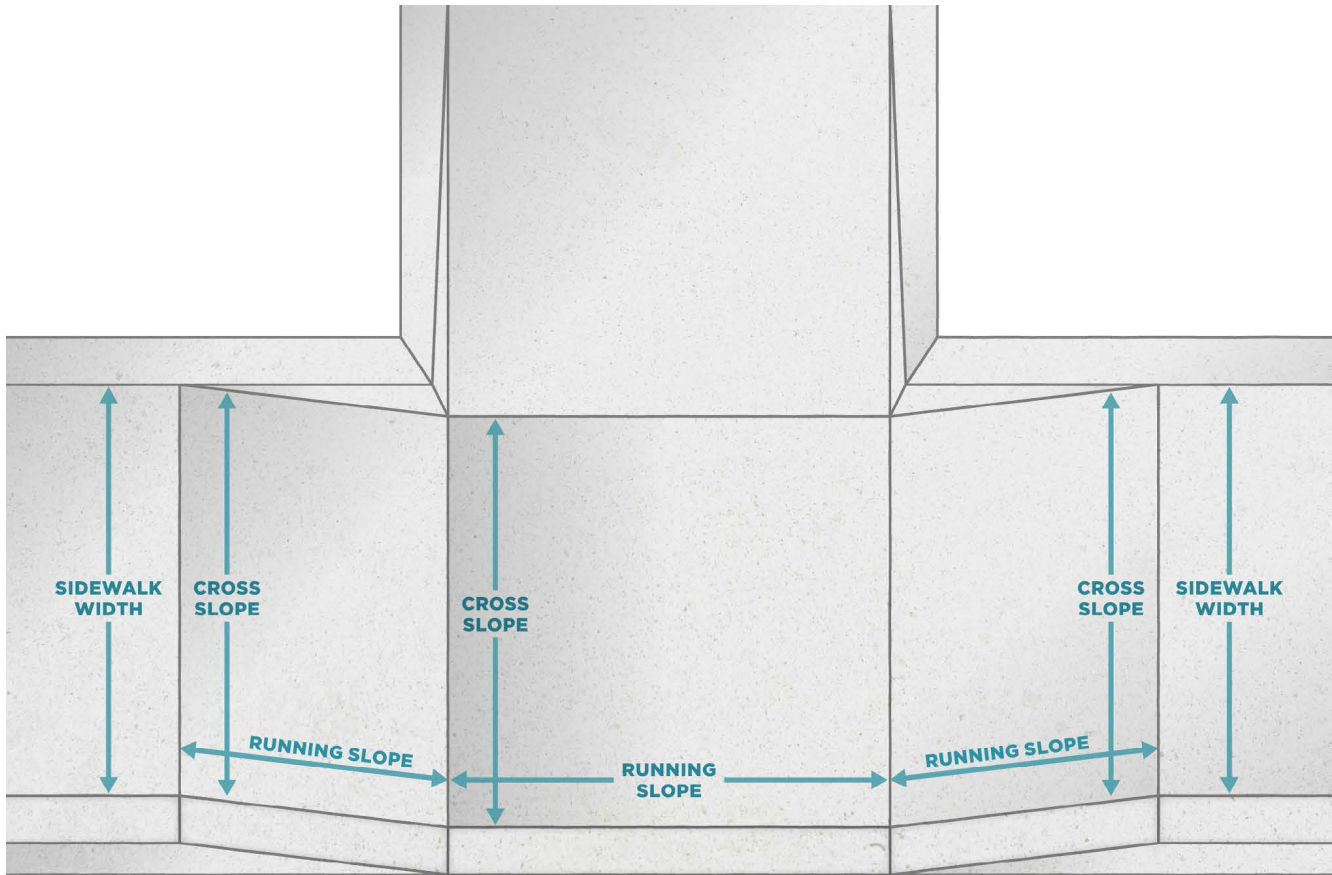

Figure 2.5 Sidewalk Attributes

Sidewalks

Field data were collected for sidewalks by Transpo Group and Kitsap County. The field data collection for sidewalks was completed along the length of each segment and then evaluated for compliance with ADA standards. Common attributes for sidewalks are shown in Figure 2.5.

Each sidewalk was reviewed for compliance, then scored based on the degree to which the barrier impeded accessibility.

- Width, i.e., the sidewalk is too narrow.
- Slope, i.e., the sidewalk run slope or cross slope is too steep.
- Condition, i.e., the amount of cracking, upheaval, or other deterioration.

Sidewalks were scored using a scale of 0-30 and categorized as follows:

- 0: Compliant.
- 1-15: Minor Compliance Issue.
- 16-30: Significant Compliance Issue.

Hazards

Data were recorded when a hazard was observed in the pedestrian access route. Features that were inventoried included vertical and horizontal discontinuities, objects, and non-compliant driveways.

Each hazard located along a pedestrian access route was reviewed for severity, then scored based on the degree to which the barrier impeded accessibility. These barriers included:

- Vertical discontinuities, i.e., elevation changes in the walkway that can cause issues such as someone tripping or impeding a wheelchair or walker.
- Horizontal discontinuities, i.e., holes, gaps, and cracks that can cause issues such as someone falling or catching a cane in the discontinuity.
- Fixed, movable, or protruding objects, i.e., objects that reduce the available walkway space such as branches, signs, poles and mailboxes.

Driveways

Data were recorded when it was determined that a driveway presented a hazard on a pedestrian access route. Features that were measured included driveway cross slopes and other driveway barriers.

Each driveway located along a pedestrian access route was reviewed for compliance, then scored based on the degree to which the barrier impeded accessibility. These barriers include:

- Non-concurrent grade breaks, i.e., when any grade changes along the pedestrian travel path are non-concurrent within the driveway.
- Driveway cross slopes, i.e., the cross slope of the driveway is too steep.
- Running slopes, i.e., the running slope is too steep.



Signal Push Buttons

Data for pedestrian signal push buttons was collected by Transpo Group staff and Kitsap County. Accessible pedestrian signal push buttons (APS) provide integrated visual, audible, and vibrotactile information to help pedestrians cross signalized intersections. Some push buttons can be programmed to request an extended crossing time or to make the name of the street being crossed audible when pushed for a longer time.

Data collectors recorded location and design attributes for each push button. Location attributes included reach distance to the button, availability of a clear and level area at the button, and the location relative to the intersection and corresponding crosswalk (see Figure 2.6). Design attributes included visual and tactile elements, such as a raised arrow pointing to the crossing, as well as features that provide audible and vibrational feedback.

Each pedestrian push button was reviewed for compliance, then scored based on the degree to which the barrier impeded accessibility.

Push button scores ranged from 0-30 and were categorized as follows:

- 0: Compliant.
- 1-15: Minor Compliance Issue.
- 16-30: Significant Compliance Issue.

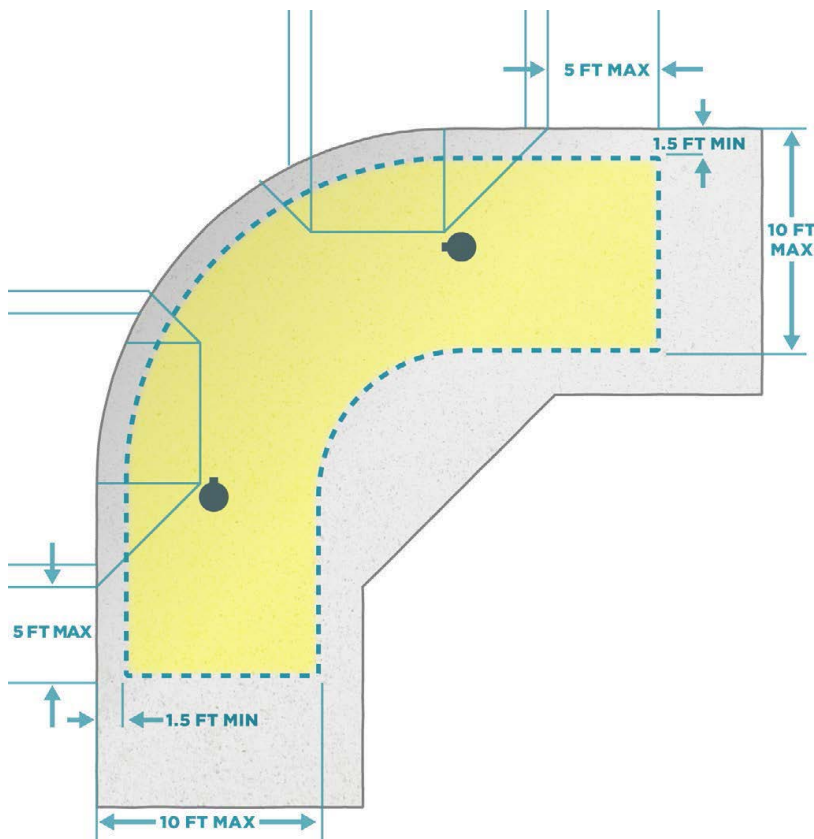

Figure 2.6 APS Pedestrian Push Button and Push Button Location Attributes

Crosswalks

Transpo Group and Kitsap County collected data for marked and unmarked crosswalks located across the county. Crossings that exist between two curb ramps but are not painted were considered "unmarked crosswalks". Features measured included width, cross slope, and running slope.

Each crosswalk was reviewed for compliance, then scored based on the degree to which the barrier impeded accessibility. These barriers include:

- Insufficient width, i.e., the crosswalk is less than six feet wide.
- Cross slope grade i.e., the cross slope is too steep.
- Running slope grade, i.e., the running slope is too steep.

Crosswalk scores ranged from 0-30 and were categorized as follows:

- 0: Compliant.
- 1-15: Minor Compliance Issue.
- 16-30: Significant Compliance Issue.



Table 2.1 Existing and Missing Curb Ramp Compliance

CURB RAMP COMPLIANCE	RAMPS	% OF TOTAL
Significant Compliance Issue	1,708	63.4
Minor Compliance Issue	712	26.4
Compliant Ramps	273	10.2
Total	2,693	100

2.3.2 Findings

Curb Ramps

Approximately 90% of the 2,693 inventoried curb ramps do not meet ADA standards (see Table 2.1 and Figures 2.7 through 2.11).

As discussed in Section 2.3.1, non-compliant ramps are those that have:

- Non-compliant ramp width, i.e., the ramping area is not present or is too narrow (Figure 2.8).
- Non-compliant running slope, i.e., the ramp running slope is too steep (Figure 2.9). 826 curb ramps have running slopes greater than 8.3%.
- Non-compliant cross slope, i.e., the cross slope is too steep (Figure 2.10). 1,137 curb ramps have cross slopes greater than 2%, 713 of which have cross slopes greater than 3%.
- Several minor non-compliant features.

Curb ramps are designed and constructed to tie into the existing roadway. As noted previously, steep or otherwise constrained locations may make it infeasible to meet ADA standards. When it is not feasible to remove all curb ramp barriers, ramps may be built to the maximum extent feasible (MEF) to satisfy accessibility requirements. This planning level Self-Evaluation did not examine whether non-compliant ramps were built to the maximum extent feasible. See Section 5.1 for additional information regarding MEF documentation.

It should be noted that data regarding missing curb ramps were also collected when a curb ramp existing on one side of a street did not have a receiving ramp on the opposite side of the street where there was an existing pedestrian access route, separated by a grade difference, on the receiving side. Missing curb ramps are recorded with maximum scoring and are in the “significant compliance issue” category. Figure 2.11 shows the locations of the missing curb ramps.

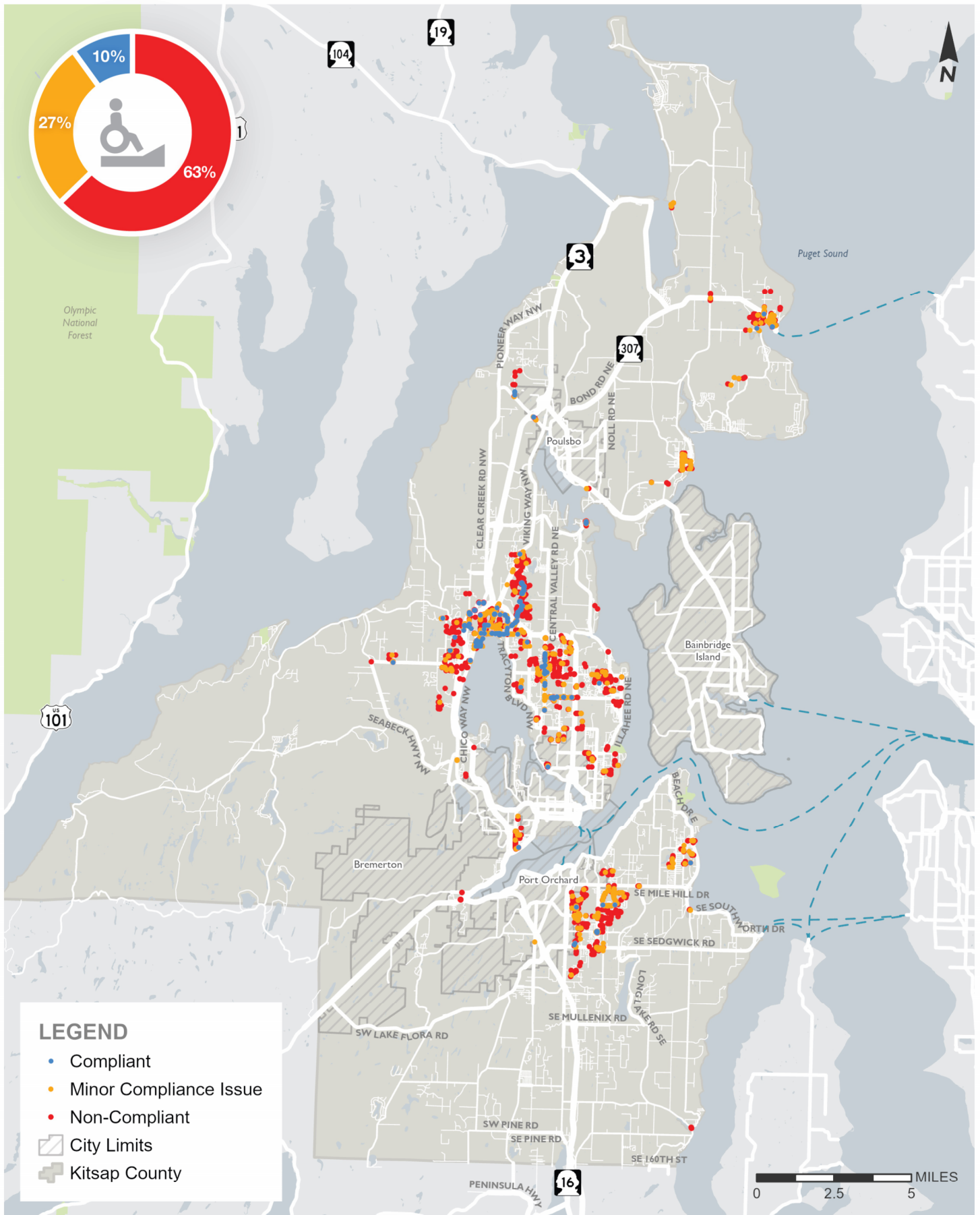

Non-Compliant Curb Ramp
 Kitsap County ADA Transition Plan

FIGURE
 2-7

DRAFT



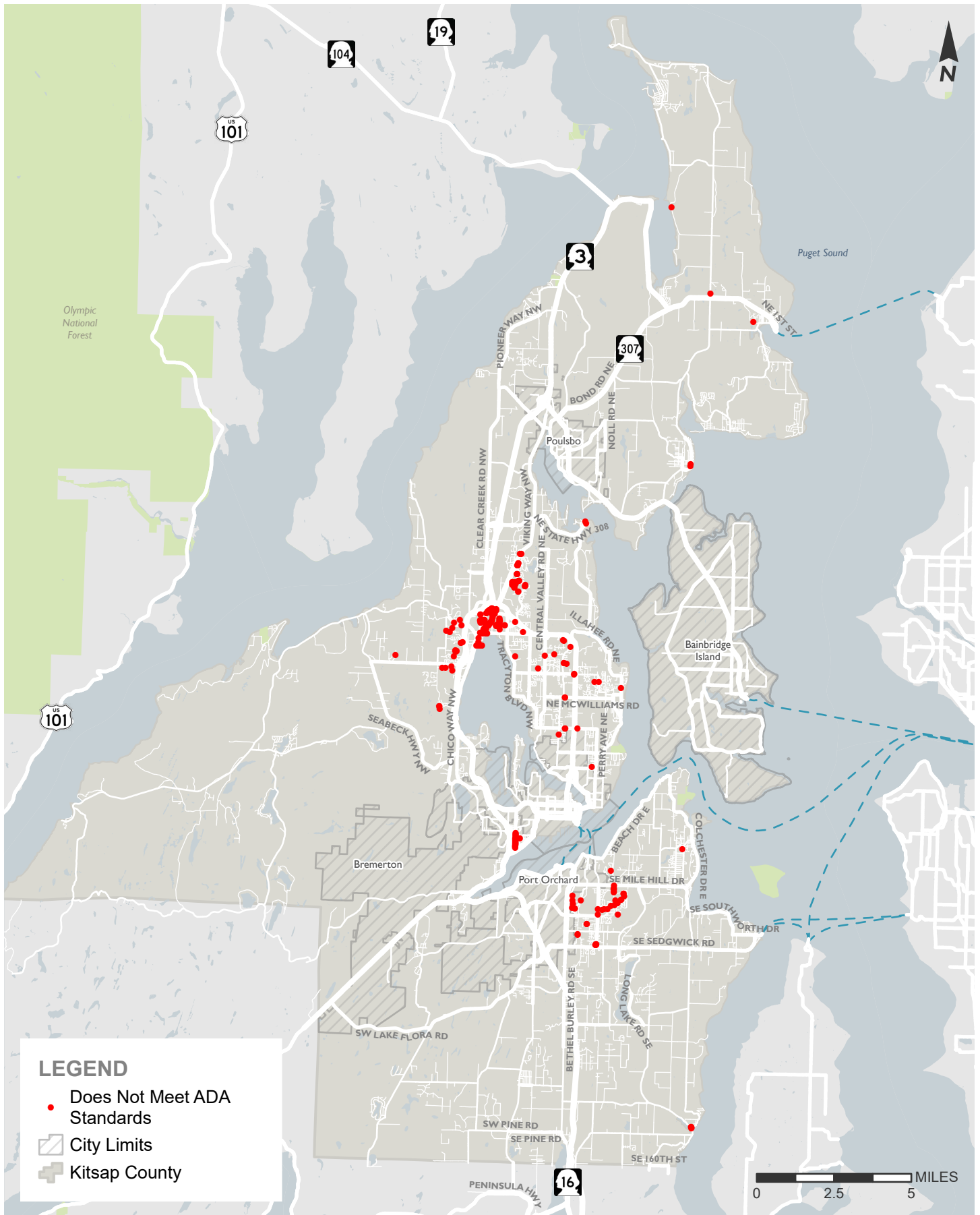

Curb Ramp with Non-Compliant Width

Kitsap County ADA Transition Plan

DRAFT



FIGURE
2-8

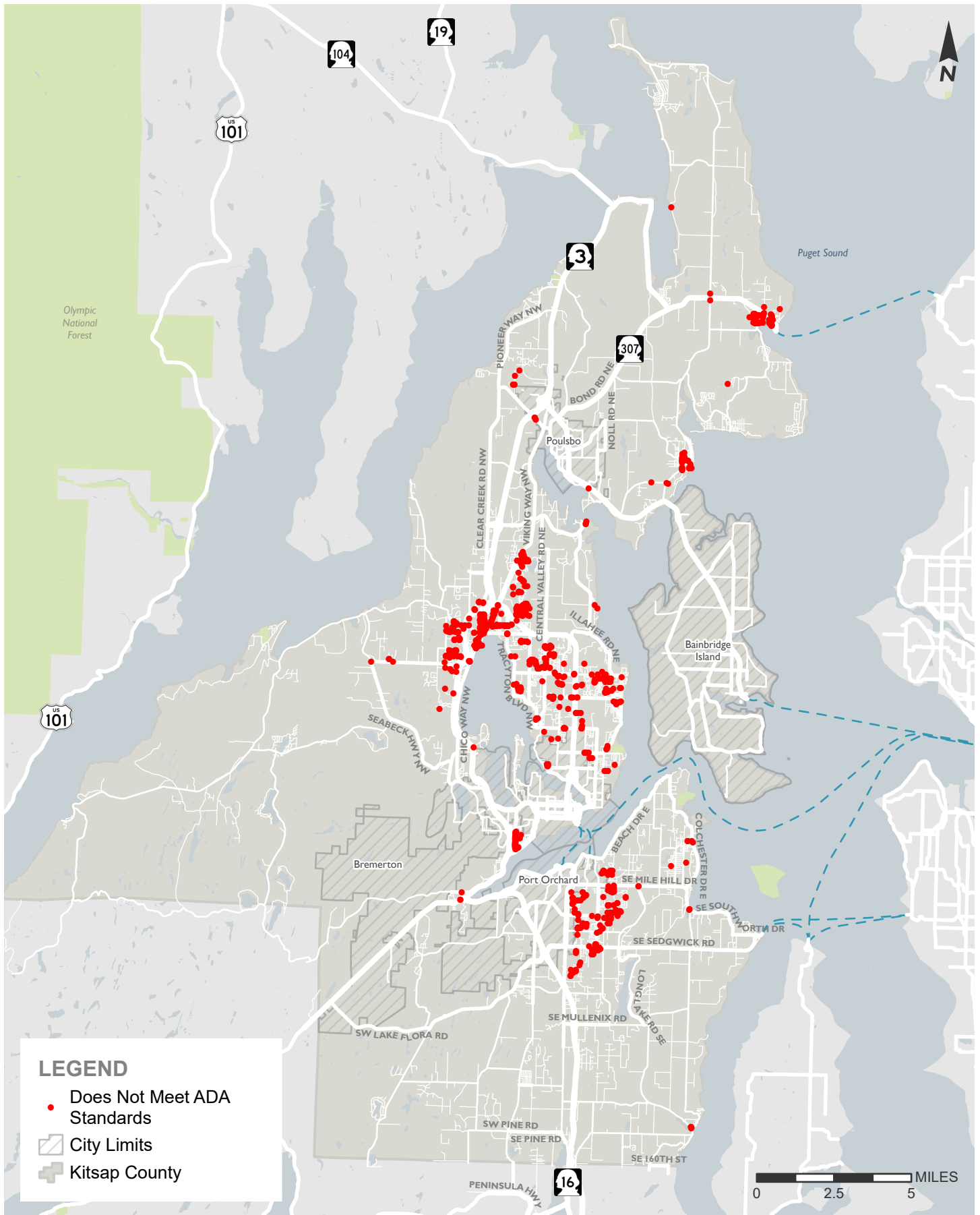

Curb Ramp with Non-Compliant Running Slope

Kitsap County ADA Transition Plan

DRAFT

transpogroup

FIGURE

2-9

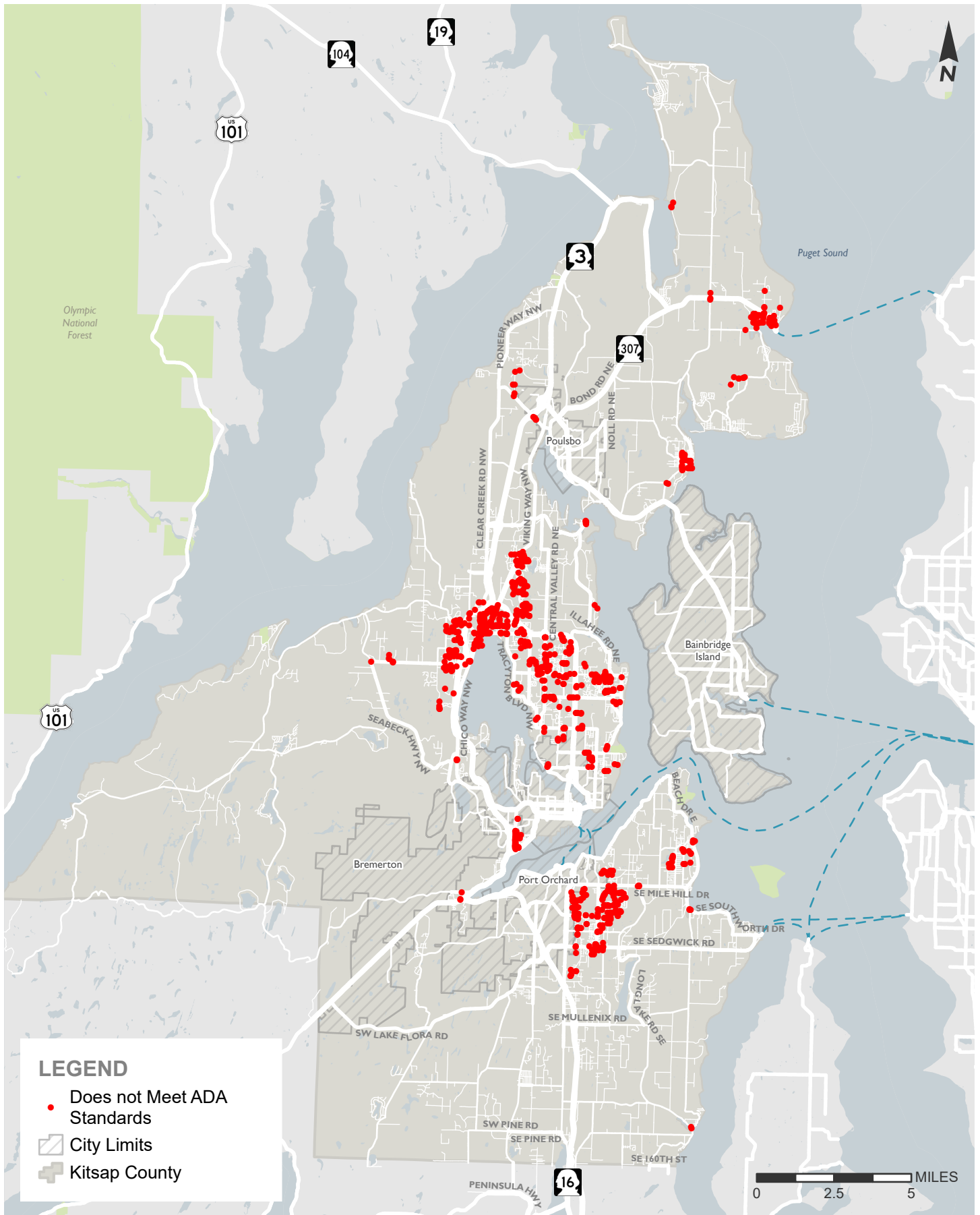

Curb Ramp with Non-Compliant Cross Slope

Kitsap County ADA Transition Plan

DRAFT

transpogroup

FIGURE
2-10

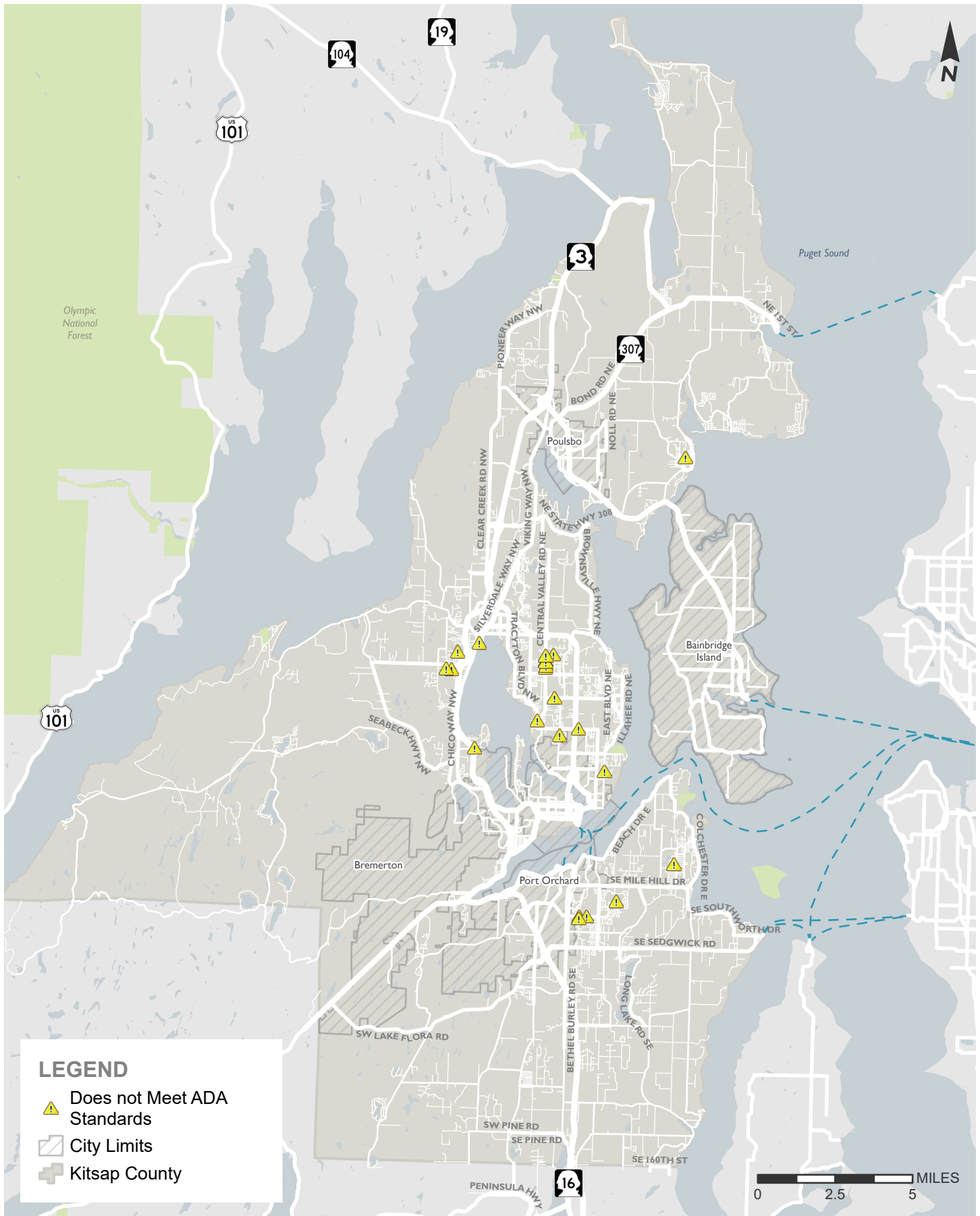

Curb Ramp with No Receiving Ramp

Kitsap County ADA Transition Plan

DRAFT



FIGURE
2-11

M:\2211.22438.00 - Kitsap County ADA Transition Plan\GIS\ArcGISPro\KitsapCountyADA\KitsapCountyADA_FigureExport.aprx

Table 2.2 Sidewalk Compliance

CURB RAMP COMPLIANCE	MILES	% OF TOTAL
Significant Compliance Issue	14.7	14.9
Minor Compliance Issue	79.1	80
Compliant	5	5.1
Total	98.8	100

Sidewalks

A total of 98.8 miles of sidewalk were inventoried, with approximately 95% not meeting ADA standards (see Table 2.2 and Figures 2.12 through 2.16). Grinding, patch repair, and full reconstruction are potential solutions for removing sidewalk barriers, depending on the severity of the barrier.

Crosswalks

Data collection for this plan included 394 crosswalks, with 158 not meeting ADA standards. A common non-compliant element among crosswalks was the cross slope.

Sidewalk Hazards

A total of 9,061 hazards (see Figure 2.15) were inventoried. Pruning, clearing, relocating objects, and full sidewalk panel reconstruction are potential solutions for removing hazards, depending on the severity and type of the hazard. Common sidewalk hazards inventoried included parked cars and prunable vegetation.

Driveways

Data collectors inventoried 1,637 non-compliant driveways during Self-Evaluation for this plan. A common element found to be in non-compliance among the driveways was the cross slope. Figure 2.16 shows the locations of non-compliant driveways. Grinding, patch repair, and full reconstruction are potential solutions for removing driveway barriers, depending on the severity of the barrier.

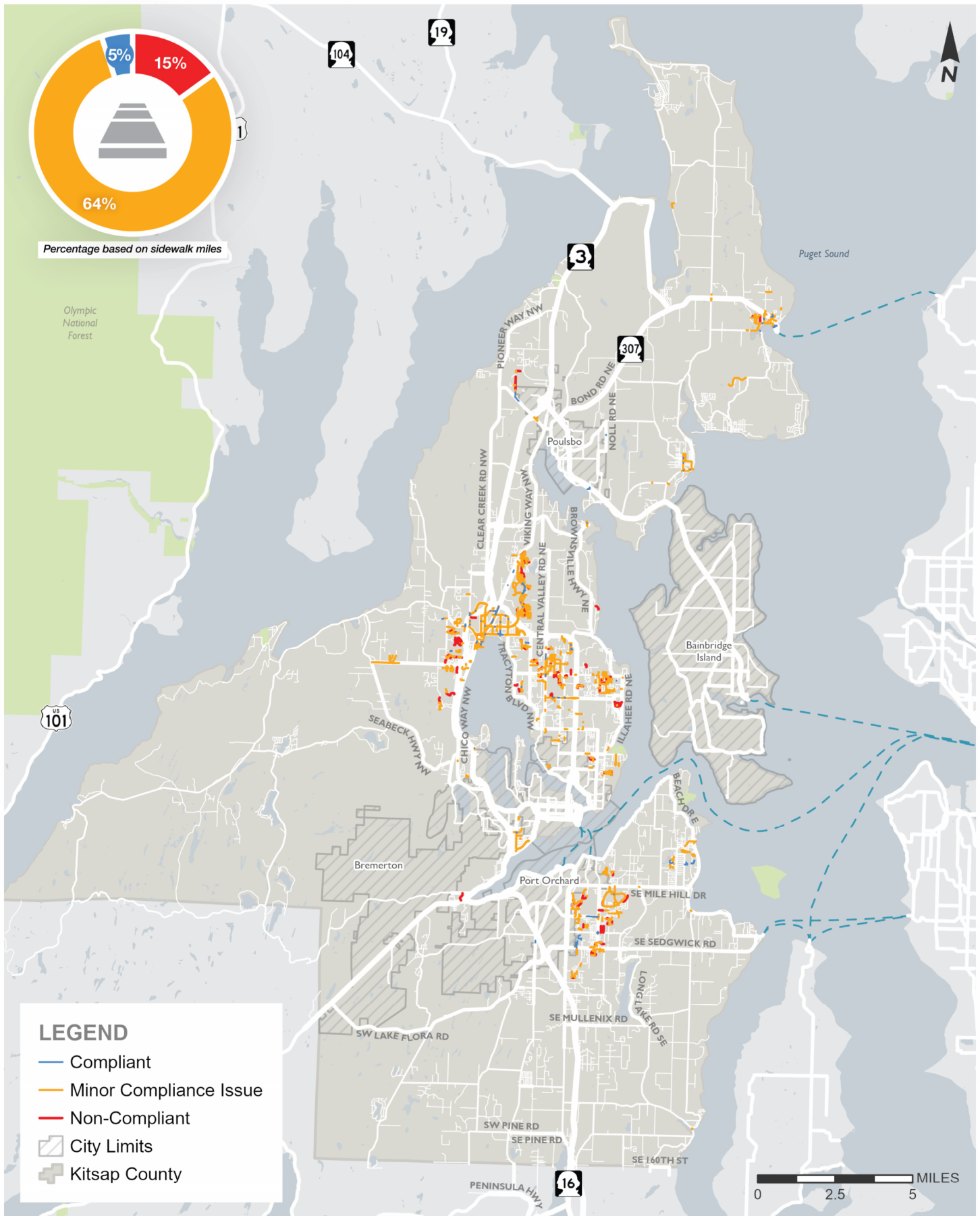

Non-Compliant Sidewalk

Kitsap County ADA Transition Plan

DRAFT



FIGURE
2-12

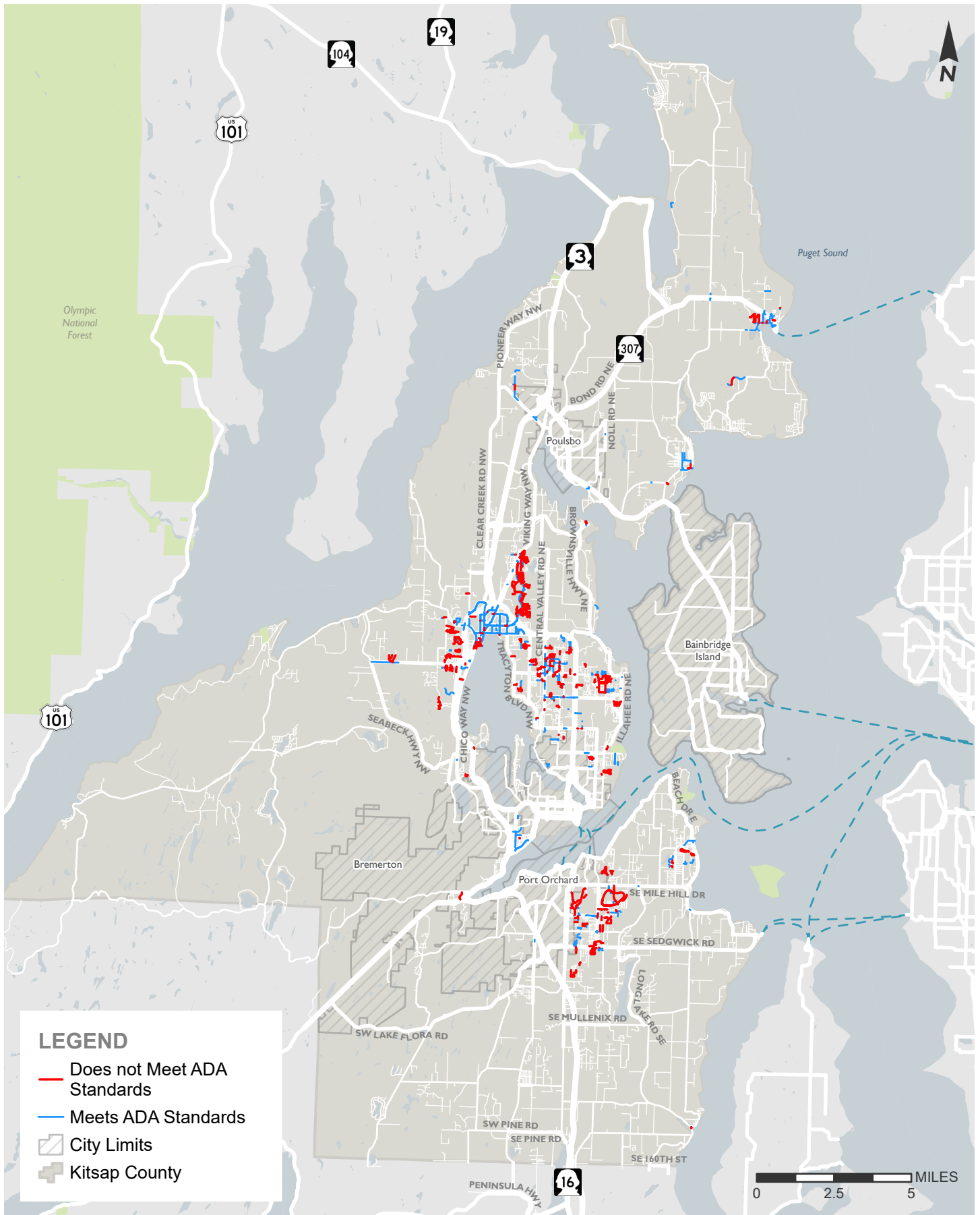

Sidewalk/Pathway Width ADA Compliance Status

Kitsap County ADA Transition Plan

DRAFT

transpogroup

FIGURE
2-13

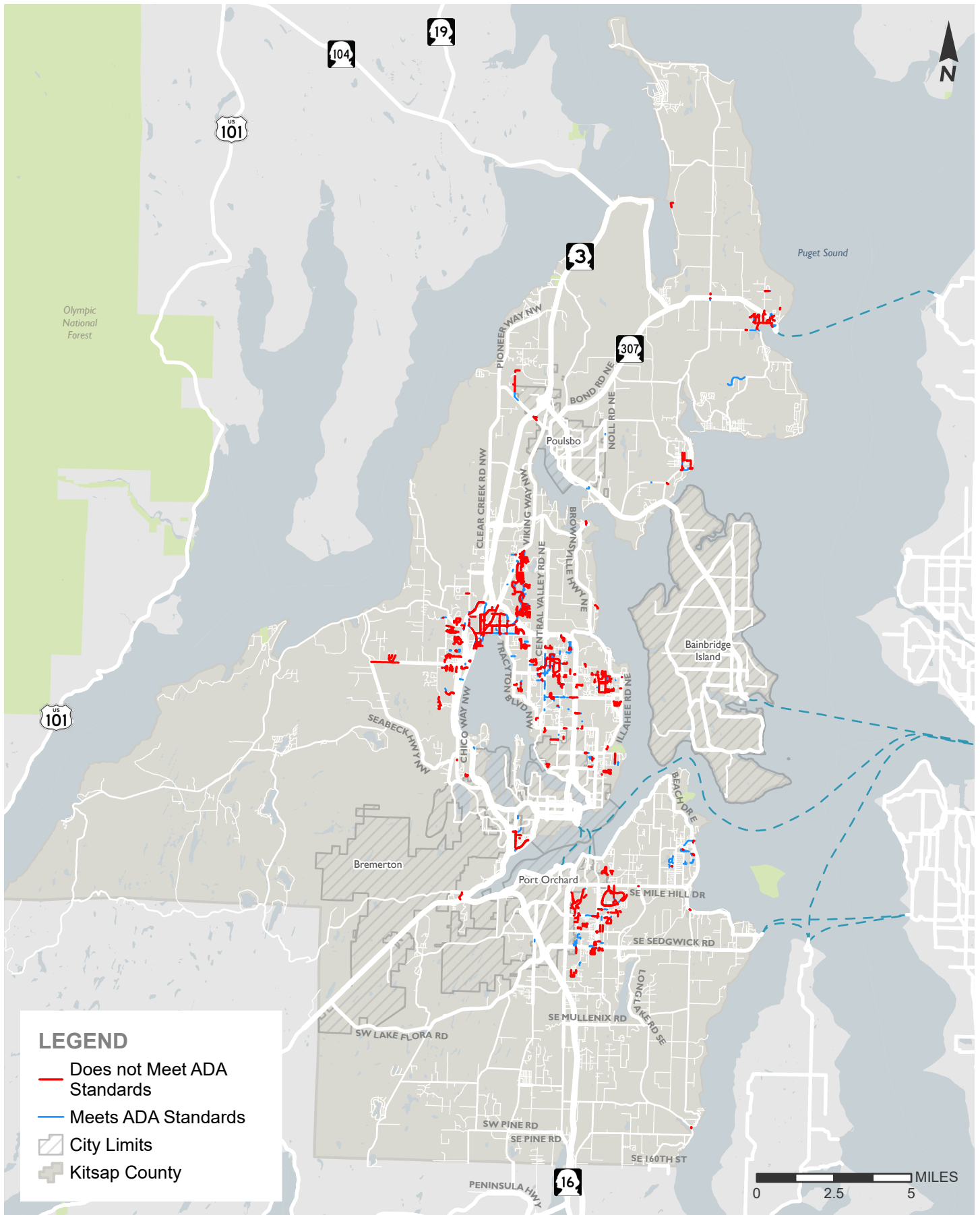

Sidewalk/Pathway Cross Slope ADA Compliance

Kitsap County ADA Transition Plan

DRAFT



FIGURE
2-14

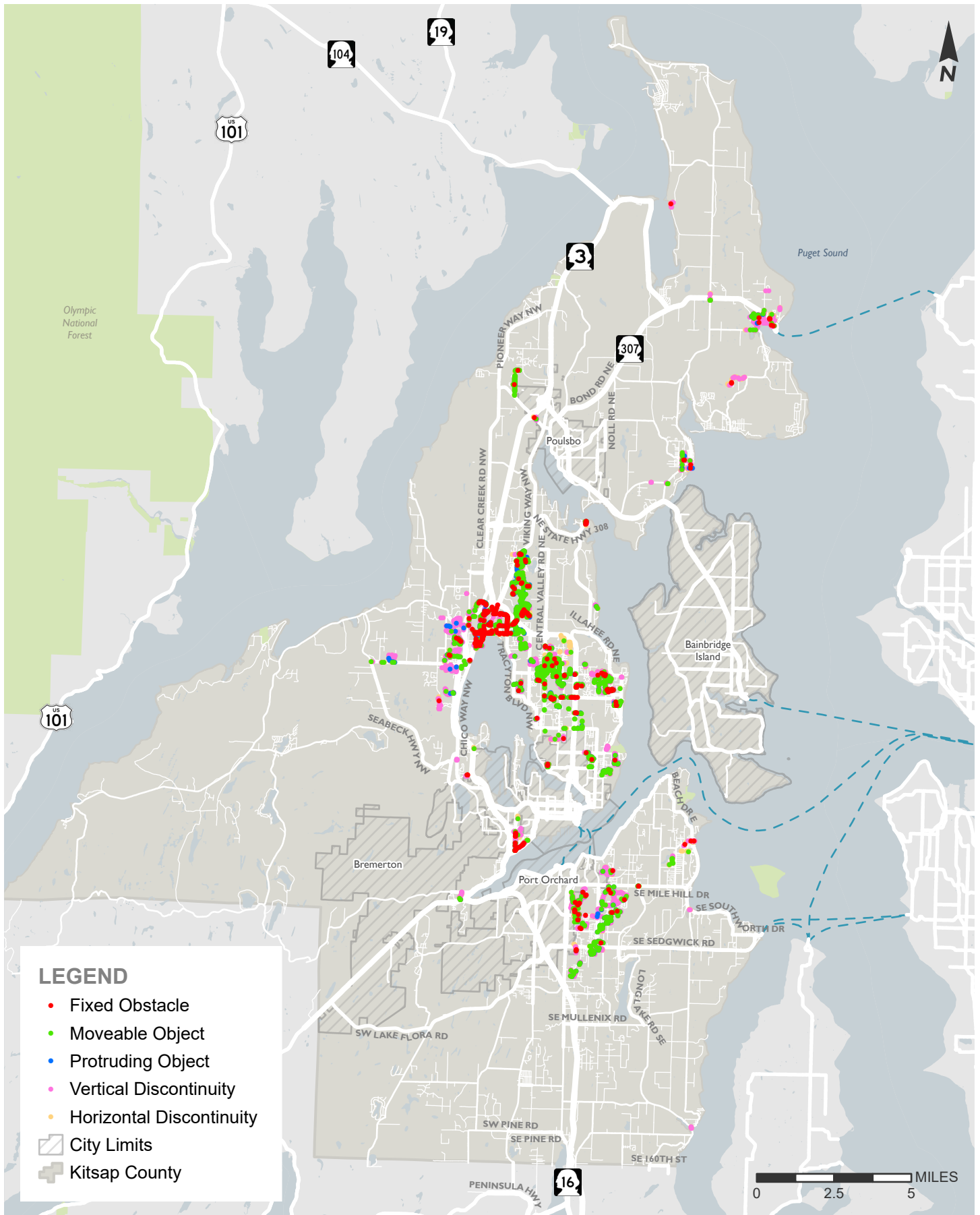

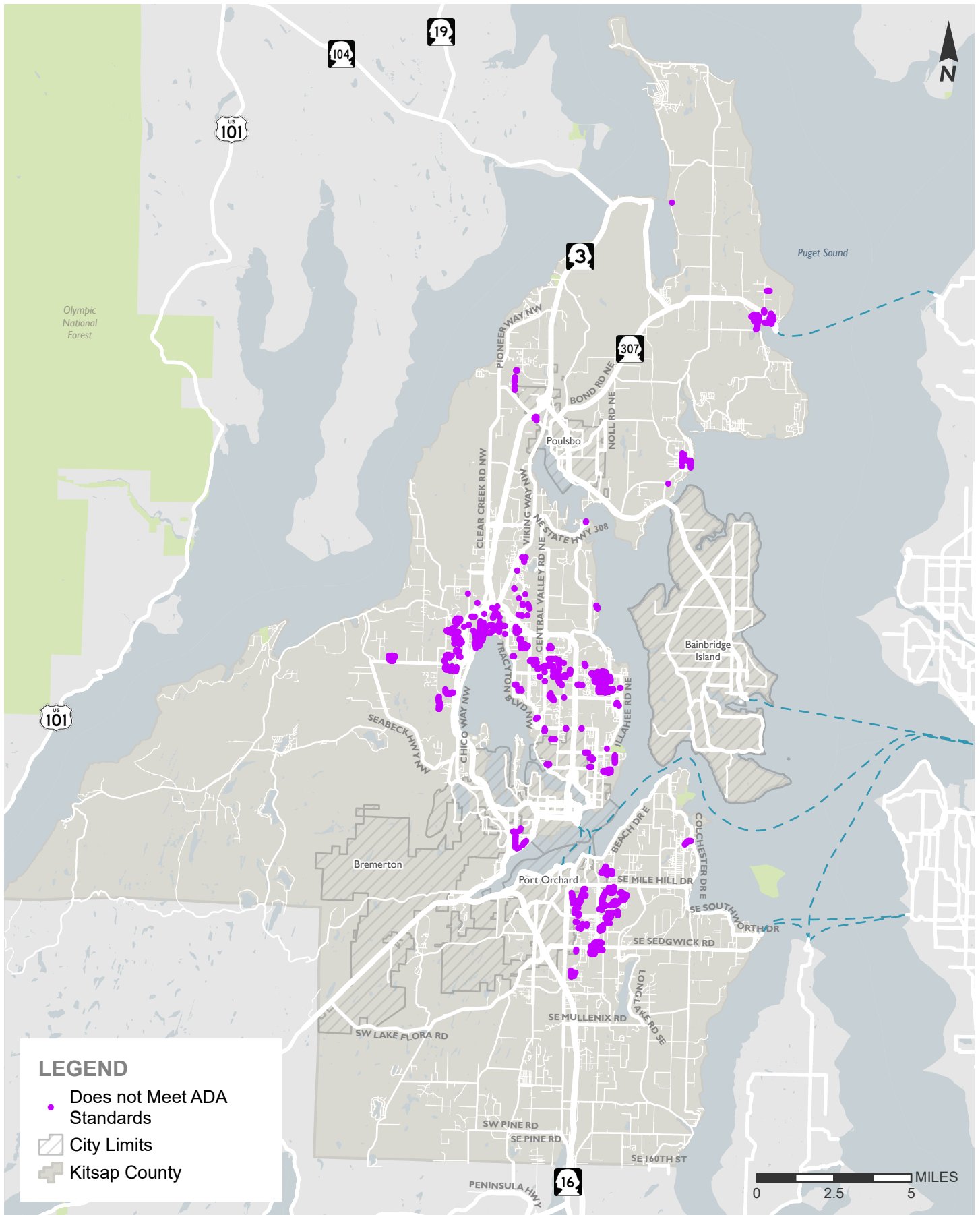

LEGEND

- Does not Meet ADA Standards
- ▨ City Limits
- ⊕ Kitsap County



Non-Compliant Driveways Along Sidewalks/Pathways
Kitsap County ADA Transition Plan

DRAFT



FIGURE 2-16



Figure 2.17 “H-style” And APS-style Pedestrian Push Button

Signal Push Buttons

Of the 334 inventoried pedestrian push buttons, 196 were non-APS style. Non-compliant pedestrian push buttons include non-APS style buttons to be replaced and APS-style buttons to be reprogrammed or relocated.

Upgrading non-APS style push buttons would fall under County responsibility when the push button is County-owned, or if it is a County-funded project located on a WSDOT facility that calls for signal upgrades.

Currently, older “H-style” design push buttons account for 58% of pedestrian push buttons in Kitsap

County. This style of push button can be upgraded to increase accessibility but must be fully replaced with an accessible pedestrian signal (APS)-style push button to achieve full ADA compliance (Figure 2.17).

The requirement to use APS-style push buttons is relatively new, and lack of compliance is typically due to a crossing not being upgraded prior to evolving requirements. Push buttons are most often upgraded to APS-style in groups rather than individually. As a result, APS-style additions and upgrades usually occur on an intersection-by-intersection basis.

Figure 2.18 shows the type and locations of pedestrian push buttons throughout the county.

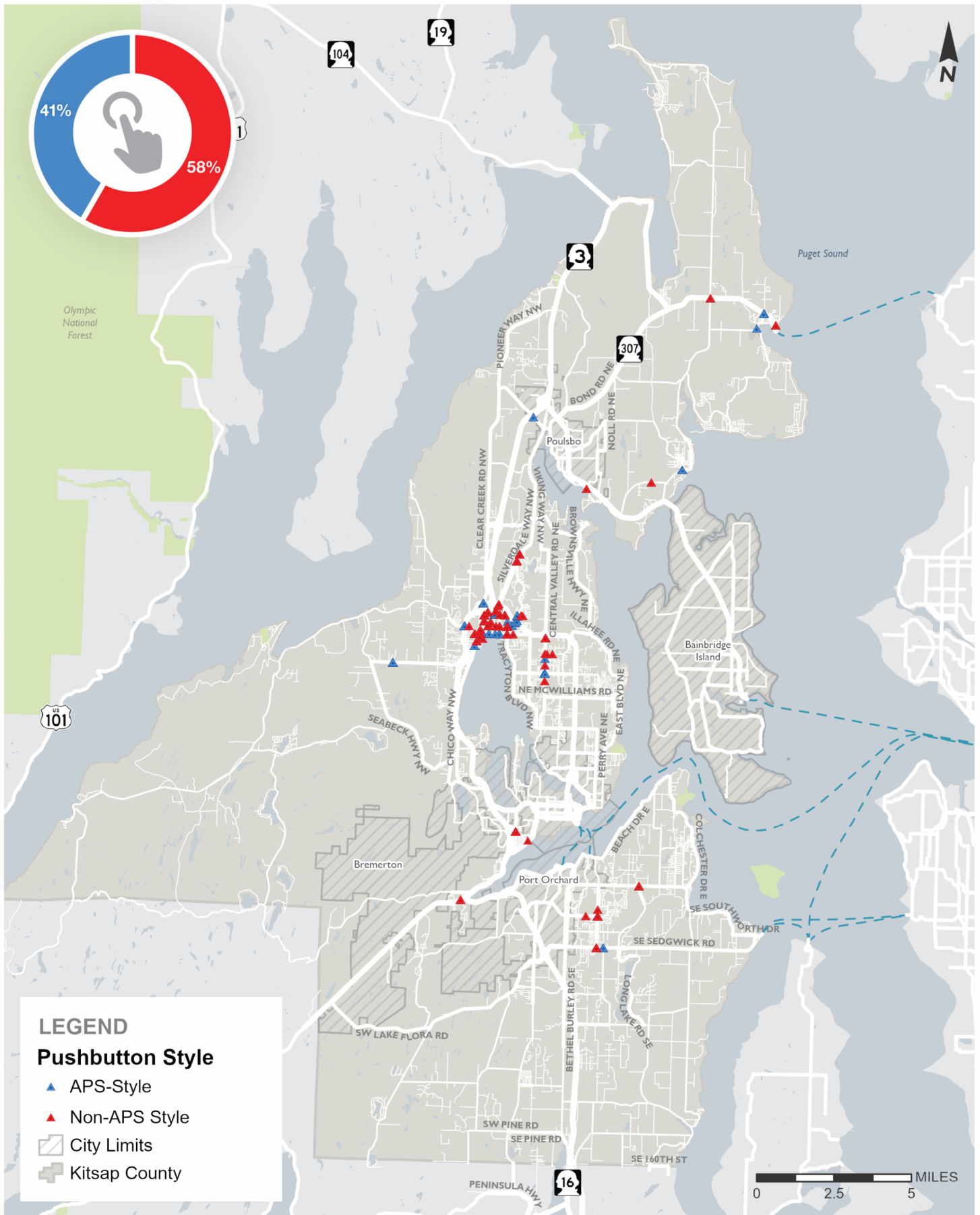

Signal Push Buttons: APS and Non-APS

Kitsap County ADA Transition Plan

DRAFT



FIGURE

2-18

3 Stakeholder Engagement

Public and stakeholder input is an essential element in the Self-Evaluation and Transition Plan development processes. ADA implementation regulations require public entities to provide an opportunity to interested persons, including individuals with disabilities or organizations representing individuals with disabilities, to participate in the Self-Evaluation process, and development of the Transition Plan, by submitting comments (28 CFR 35.105(b) and 28 CFR 35.150(d)(1)). There were three primary goals for the public outreach activities prior to adopting the plan:

- Inform the public about the County's plan and processes regarding the removal of accessibility barriers within the right-of-way and provide information to assist interested parties in understanding the issues faced by the County, the barrier removal alternatives considered, and the County's planned actions.
- Obtain public comment to identify any errors or gaps in the proposed accessibility Transition Plan for the public right-of-way, specifically on prioritization and grievance processes.
- Meet Title II requirements for public comment opportunity.

3.1 Engagement Methods

To generate public involvement and capture public feedback on the ADA Transition Plan, Kitsap County used a variety of engagement strategies. Promotion and advertising for these outreach methods utilized the County's website and social media channels, as well as commissioners' direct e-mail lists. Kitsap County developed a [project website](#) to provide easy online access to project information and ways to provide feedback. The County also established an ADA Committee, comprised of volunteers from the disabled community, who were invited to comment on the scoring matrix and draft Transition Plan. A full account of the public engagement findings can be found in Appendix D.

3.1.1 Online Open House and Survey

An online open house that explained the ADA Transition Plan project and outlined the project's goals and focus areas was made available on the County's website. The website also provided an opportunity for the public to give feedback on accessibility barriers through a survey and pinpoint issues at specific locations with a mapping tool.

The survey contained questions focusing on the following areas:

- Whether they have a disability or support someone with one.
- Which type of accessibility barriers they currently experience.
- How they rate the accessibility conditions of existing right-of-way facilities.
- What facility types they believe should be prioritized when removing accessibility barriers.

The survey was made available for public participation from October 2023 through March 2024 and reached a total of 198 respondents, 100% of whom were Kitsap County residents. The greatest amount of input was received from the Bremerton, Poulsbo, and Kingston areas. While survey respondents were invited to share their zip codes, they were not asked to identify whether they resided in an incorporated or an unincorporated area of Kitsap County, therefore many of the comments received through the survey referred to facilities located in incorporated areas.

Survey respondents were asked to identify the reasons they typically travel in or through Kitsap County and identified their first and second priorities for improving pedestrian facilities within the county. The weighted rank priorities showed that the following three categories were highest priority:

- Government buildings that provide human services (e.g.: city halls, libraries, etc.)
- Hospitals and other medical facilities
- Retail services (e.g.: shops, restaurants, grocery stores)

4 Pedestrian Barrier Removal Methods and Schedule

Chapter 4 provides a summary of barrier removal methods and priorities to guide the implementation of barrier removal activities. This chapter presents a total planning level cost estimate for the removal of existing pedestrian barriers and provides a schedule that outlines the time frame to achieve compliance with ADA standards through the identified barrier removal methods.

4.1 Barrier Removal Methods

The County currently has a number of ongoing methods to remove accessibility barriers in the public right-of-way. Current methods of barrier removal are indirect and are typically related to other programs such as maintenance activities, and projects constructed as part of the Capital Improvement Plan. These projects, when impacting existing pedestrian facilities, will include accessibility upgrades as required.

Occasionally, permitted development will result in the reconstruction of pedestrian facilities and therefore removal of any barriers that existed in the replaced facility. However, barrier removal through this method is infrequent and not consistent from year-to-year.

Certain programs may provide continual means of barrier removal, while others vary based on outside influences, such as permitted development and the successful pursuit of grant funding.

The precise manner in which an existing pedestrian barrier is removed is typically determined by its

complexity and cost. Less complex pedestrian barriers, such as a missing detectable warning surface (DWS), can be addressed through maintenance and operations programs. Removal of more complex barriers, such as those associated with ramp or sidewalk design, typically require additional engineering and are incorporated as part of a more costly capital construction project.

For these methods to be effective, Kitsap County practices and design standards must comply with federal ADA guidance. If standards are not updated and enforced, new or reconstructed pedestrian facilities may not be constructed to accessible standards, requiring costly revision and increasing the duration it will take the County to remove all accessibility barriers.

The following sections provide additional detail regarding capital projects, maintenance, and County programs.

4.1.1 Capital Facilities Program

The Capital Facilities Program (CFP) defines projects and identifies funding for different elements of the government including the Transportation Improvement Program (TIP). Transportation projects listed in the CFP may range from minor street widening to street extension projects. After conducting a call for projects, the County Public Works department creates a list of candidate projects, inclusive of all submissions, that are evaluated and scored on a range of criteria that includes accessibility, demographic equity, non-motorized solutions, and other values. Scores are used to create a ranked candidate project list that is used to support determining what projects are advanced to the TIP. Projects that demonstrate that they address 5 or more ADA barriers identified in the Transportation Plan earn additional points. The completion of this Self-Evaluation and Transition Plan provides another useful tool that assists the County in identifying accessibility barriers for inclusion in TIP projects.

Kitsap County updates its TIP annually and forecasts projects for a six-year period. ADA compliant improvements (new or replacement) are often included as a component of these projects.

4.1.2 Sidewalk Maintenance Program

Operational and maintenance activities typically resolve less costly and less complex barriers to

accessibility. A subset of the work completed by the Public Works & Utilities department helps to remove ADA related barriers through curb, street, and sidewalk repairs. Though maintenance investments for pedestrian facilities often do not bring sidewalks, ramps, and other pedestrian infrastructure fully up to ADA standards, these investments of staff time and resources typically result in critically important access improvements. These activities include sidewalk panel grinding, panel replacement, and request-based curb ramp installations. Maintenance investments are crucial to increasing the longevity of the existing pedestrian network and can provide an opportunity to demonstrate consistent progress toward implementing the ADA Transition Plan.

4.1.3 Permitted Development

Even with complete funding availability for accessibility improvements, it will take many years to remove accessibility barriers. Redevelopment of properties, such as construction of new housing, commercial buildings, or major remodels, can provide a valuable boost to barrier removal efforts. At times, private development results in street frontage improvements as a function of construction permit requirements. All such improvements are designed and built to meet County and ADA standards. This approach to barrier removal is incremental and depends on the outside influence of developers and therefore was not included in the County's funding estimate.

4.2 Barrier Removal Plan and Schedule

The ADA requires agencies to specify a schedule for taking the steps necessary to make existing facilities ADA compliant. This plan section summarizes the three-step process used to develop a barrier removal implementation plan and schedule, consistent with ADA Transition Plan requirements:

1. Prioritization of pedestrian barriers. Physical barriers identified through the Self-Evaluation were prioritized based on the degree to which they physically impacted accessibility and their proximity to key pedestrian destinations. Community input received through stakeholder engagement informed the prioritization process.
2. Estimation of planning level costs to remove pedestrian barriers. Unit costs were applied to the barrier inventory to generate a total planning level cost estimate to remove Self-Evaluation identified barriers. This planning level cost estimate is the total estimated 'need' for barrier removal.
3. Development of a schedule for barrier removal. An estimate of available financial resources was generated and compared to the total estimated need to develop a schedule for barrier removal.

4.2.1 Prioritization of Pedestrian Barriers

To inform the County's future project selection and understand the impact of barrier removal programs, a two-part prioritization system was developed and used to score each pedestrian facility. This system was informed by the Self-Evaluation data, the community engagement process, and technical expertise. The two parts to the scoring system reflect both a facility's physical characteristics, and its importance to pedestrian travel within

the community, determined through stakeholder engagement. Under the prioritization system, each barrier was scored independently on two factors:

- **Physical impact to accessibility**, includes items such as: cross slopes, width measurements, presence of markings or hazards, etc.
- **Proximity to key pedestrian destinations**, defined through community engagement, includes proximity of destinations such as: transit stops, parks, grocery stores, and schools.

The two resulting scores were added together to incorporate both factors into a single combined score for prioritization. Based on each facility's combined score, it was then categorized as very high, high, medium, or low priority for barrier removal. Under this system, facilities that present greater barriers to accessibility and are located near multiple key pedestrian destinations are considered highest priority, while facilities with less significant physical barriers, or those located farther from key pedestrian destinations are considered a lower priority. Prioritization scoring factors are described below.

Physical impact to accessibility: Accessibility Index Score (AIS)

The Accessibility Index Score describes the degree to which each facility presents a physical barrier to accessibility. Criteria and weights were developed for sidewalks, curb ramps, and pedestrian push buttons. These criteria and weights are shown in Appendix C.

Potential scores for each facility range from 0 (compliant) to 30. Each facility's Accessibility Index Score is the sum of the individual criterion scores.

Figures 4.1 through 4.4 show the AIS for each of the facilities where data were collected.

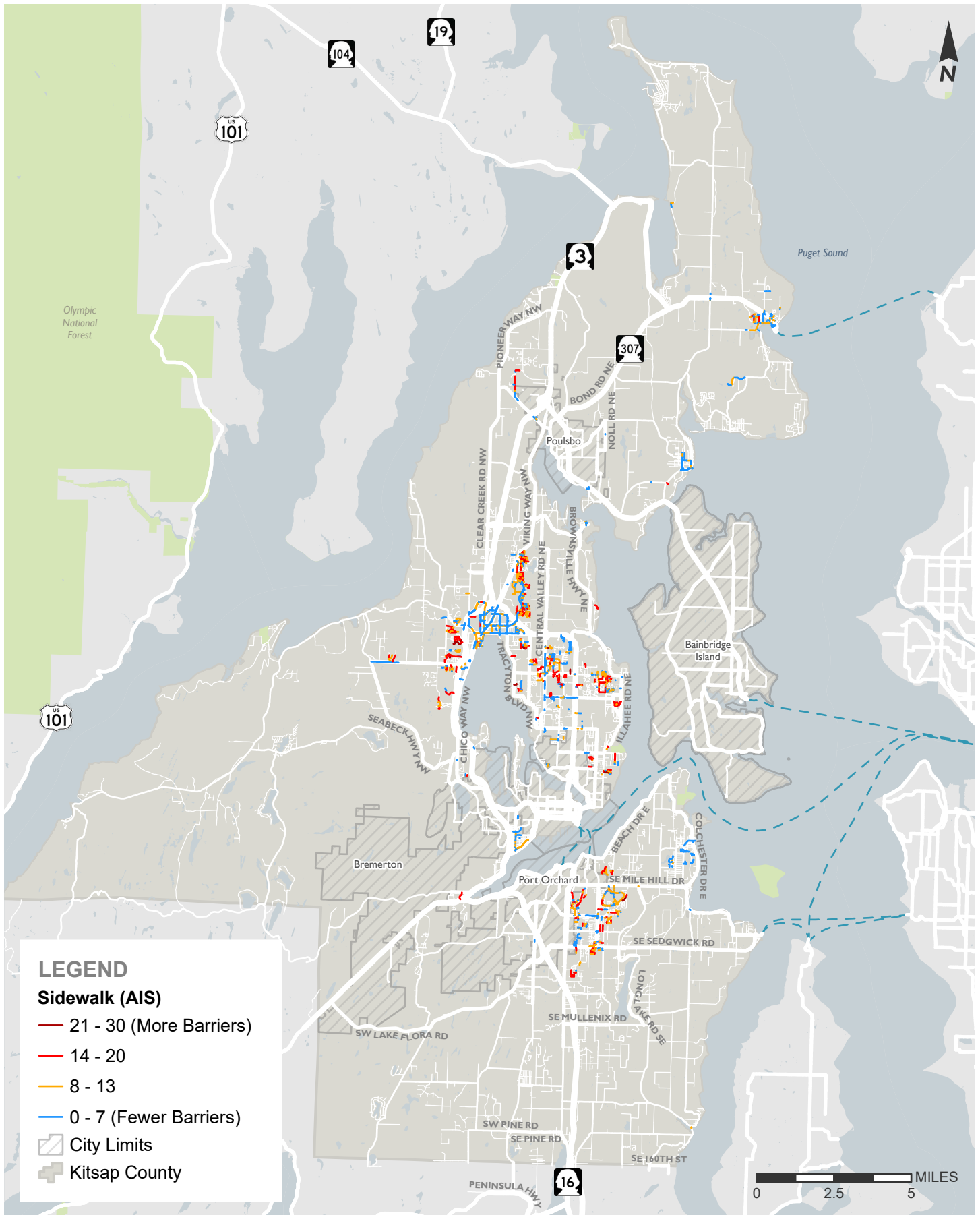

Accessibility Index Score Composite (Sidewalk/Pathway)
Kitsap County ADA Transition Plan

DRAFT



FIGURE
4-1

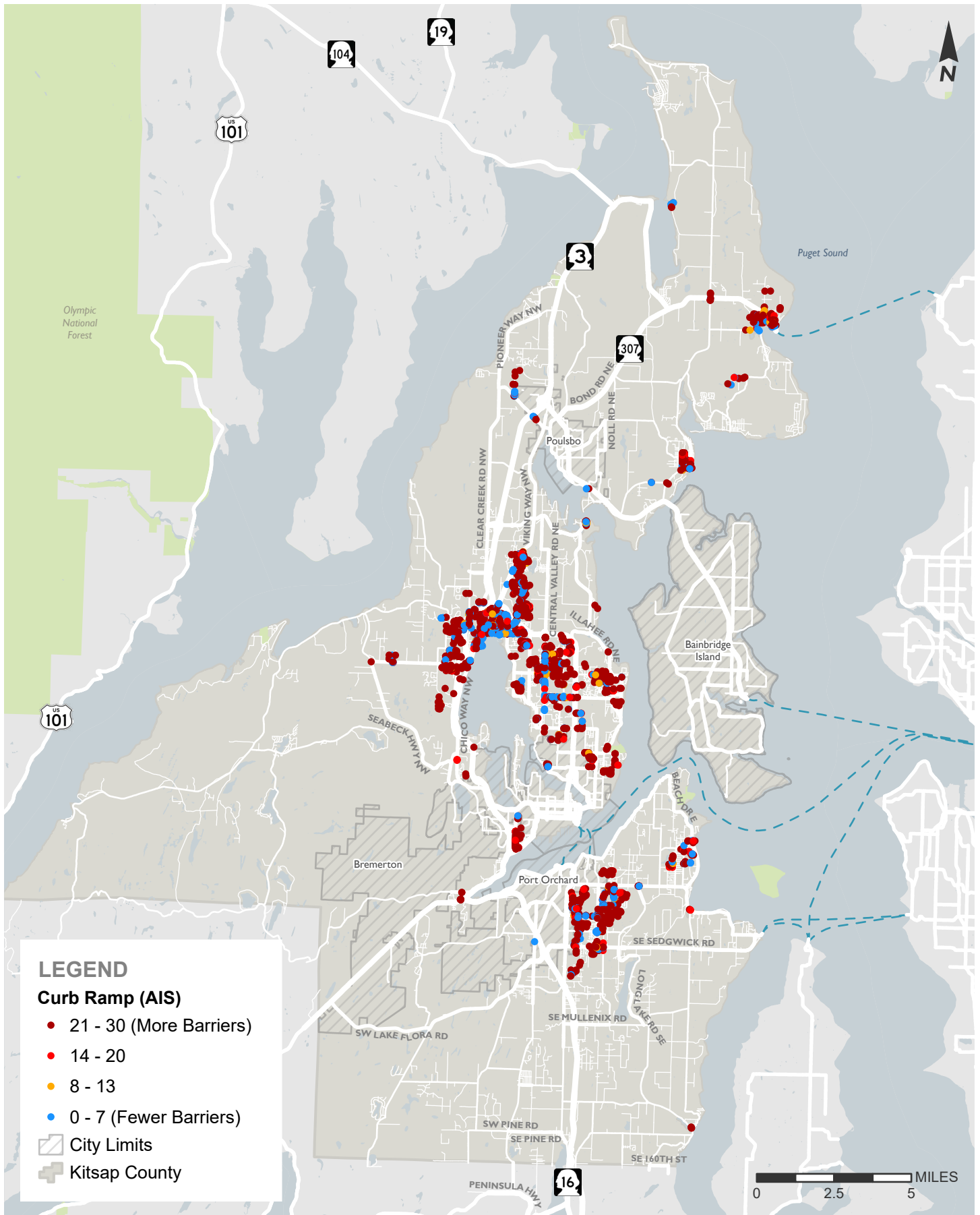

Accessibility Index Score Composite (Curb Ramp)

Kitsap County ADA Transition Plan

DRAFT



FIGURE
4-2

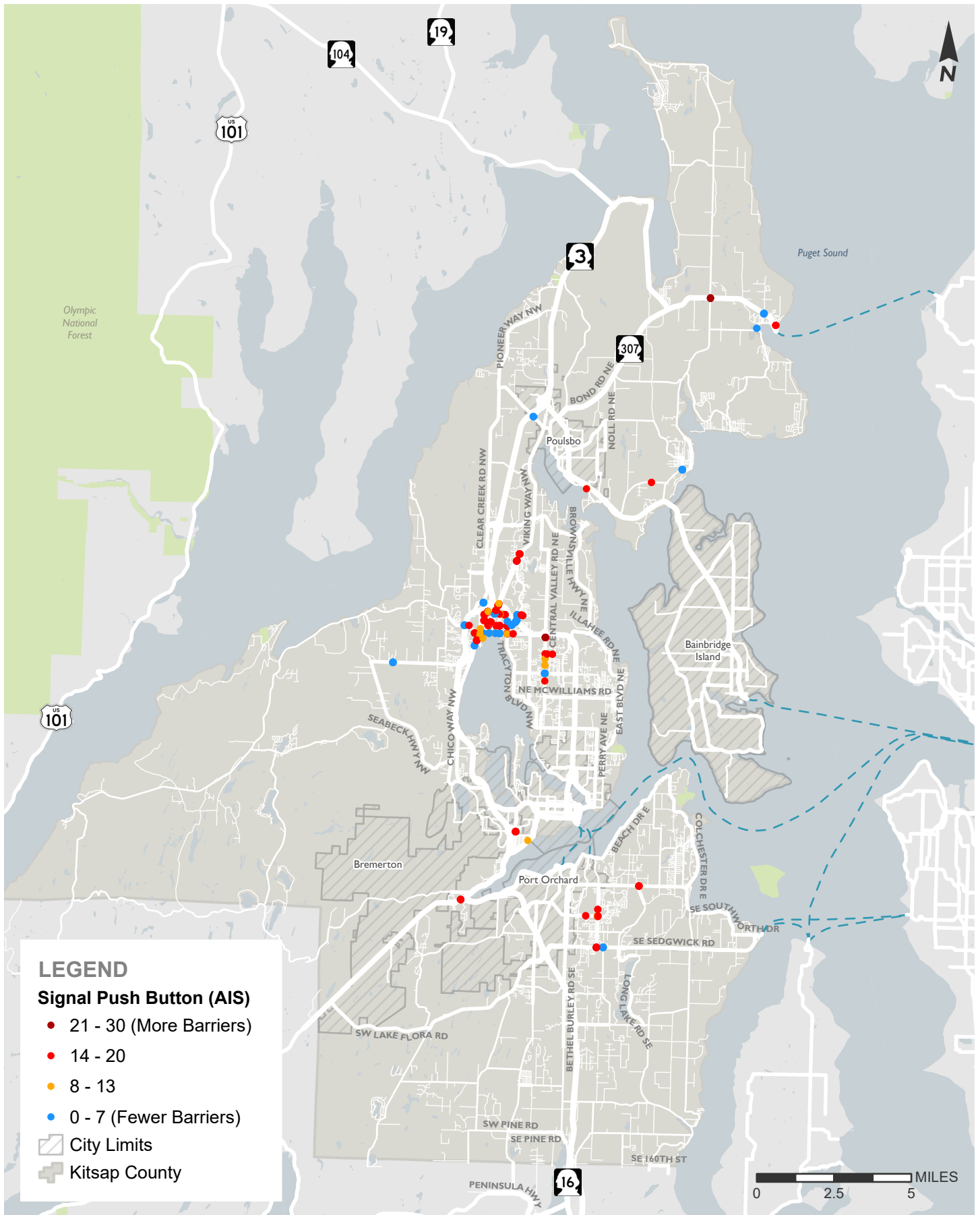

Accessibility Index Score Composite (Signal Push Button)
Kitsap County ADA Transition Plan

DRAFT



FIGURE 4-3

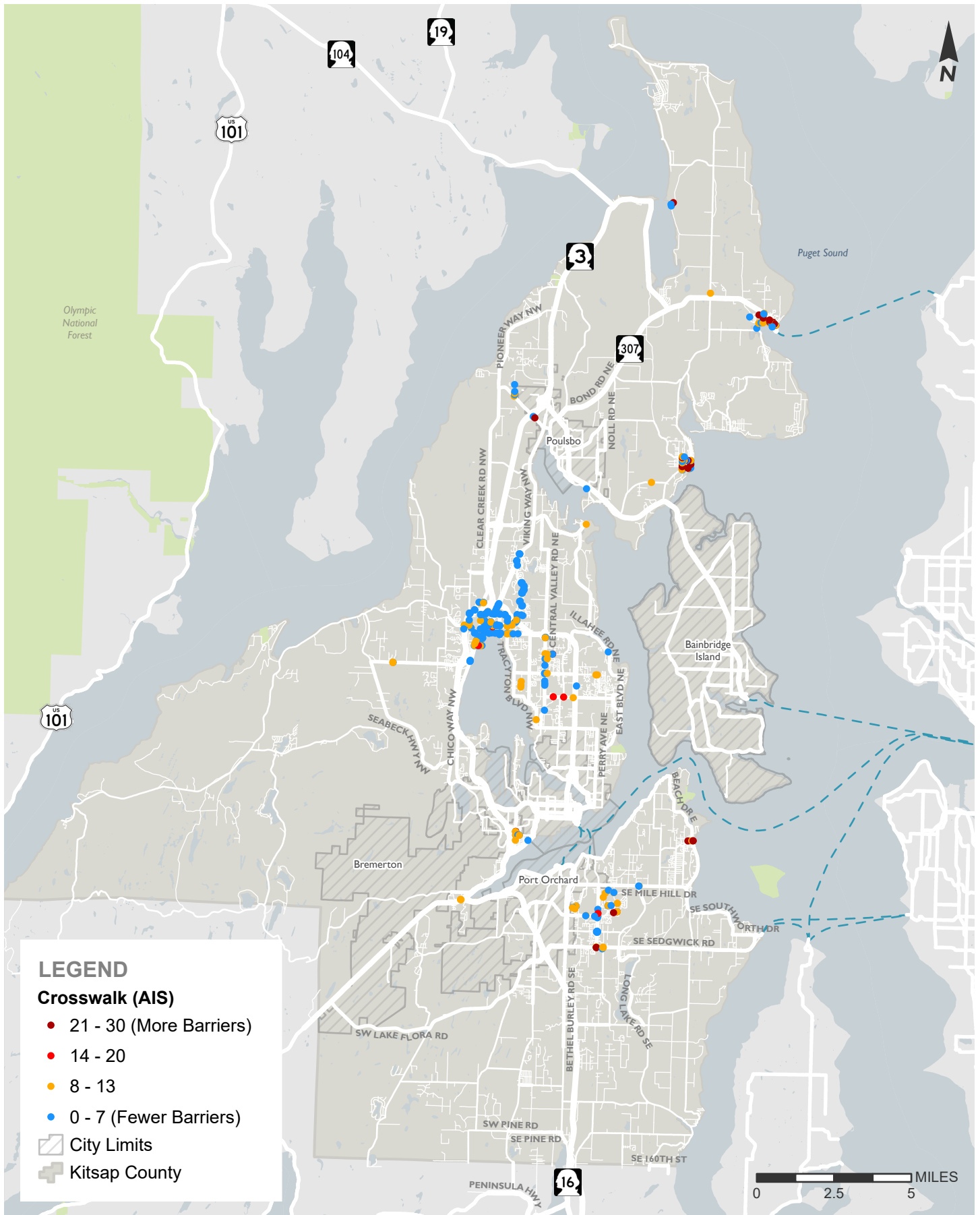

Accessibility Index Score Composite (Crosswalk)

Kitsap County ADA Transition Plan

DRAFT



FIGURE

4-4

Proximity to Key Pedestrian Destinations: Location Index Score (LIS)

The Location Index Score describes the importance of the pedestrian facility in accessing key community destinations. Each existing pedestrian facility was scored based on its proximity to schools, parks, transit facilities, signals or roundabouts, public buildings, and downtown or commercial business centers. Facilities near government buildings, hospitals and medical facilities, and retail services received a higher score to reflect feedback received through the public engagement survey.

Location Index Scores reflect the number of types of key pedestrian destinations within a defined radius. The full score for each type of destination is assigned if at least one facility of that type is nearby; scores do not increase if a facility is within the radius of multiple destinations of the same type. For example, a facility within one-eighth mile of two parks will receive a score of 5, while a facility within one-eighth mile of a park and a school will receive a score of 10.

Total Location Index Scores ranged from 0 to 45. Location scoring criteria and weights are shown in Appendix C.

Figures 4.5 through 4.9 show the LIS for each of the facilities where data were collected.

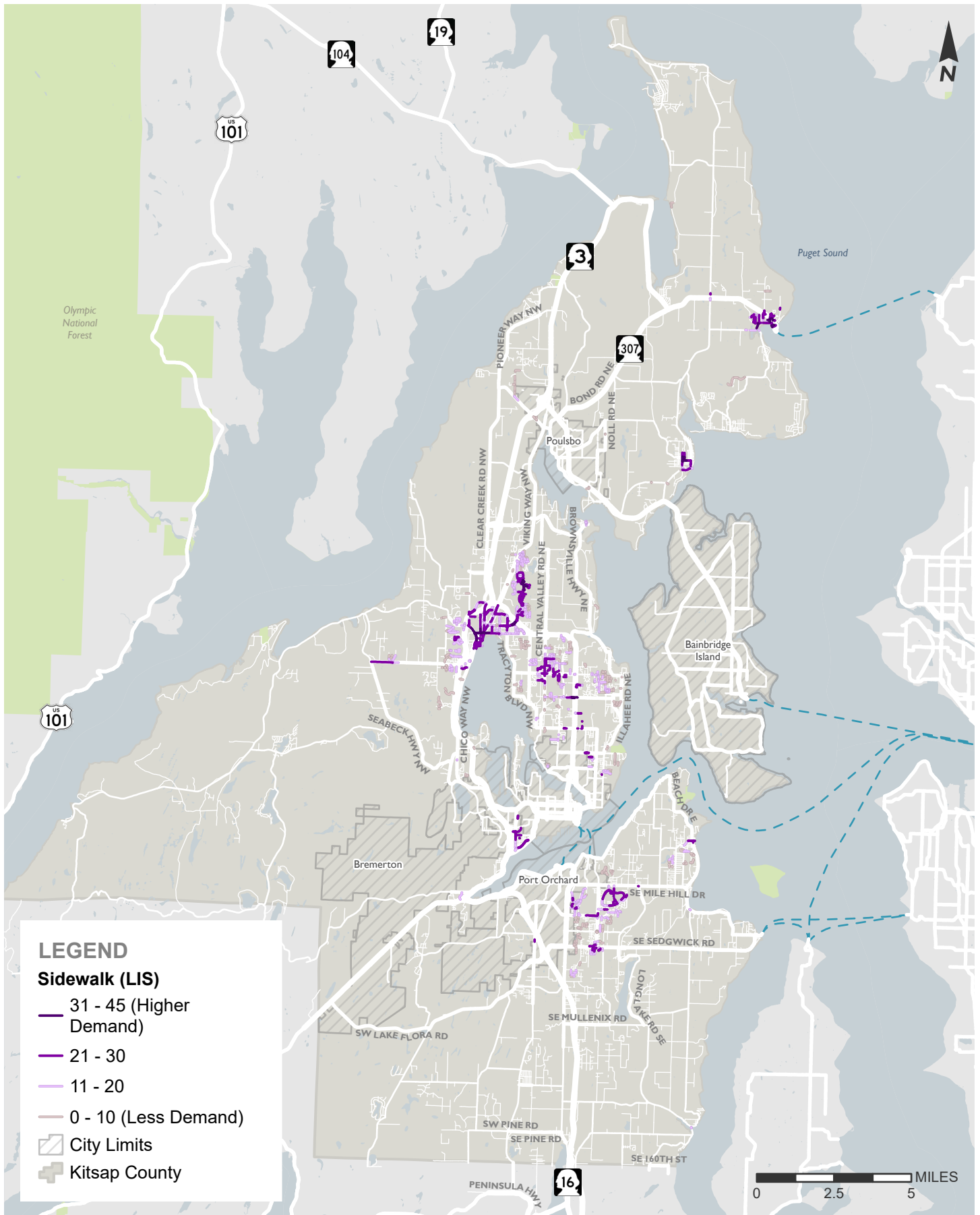

Location Index Score Composite (Sidewalk/Pathway)

Kitsap County ADA Transition Plan

DRAFT

transpogroup

FIGURE

4-5

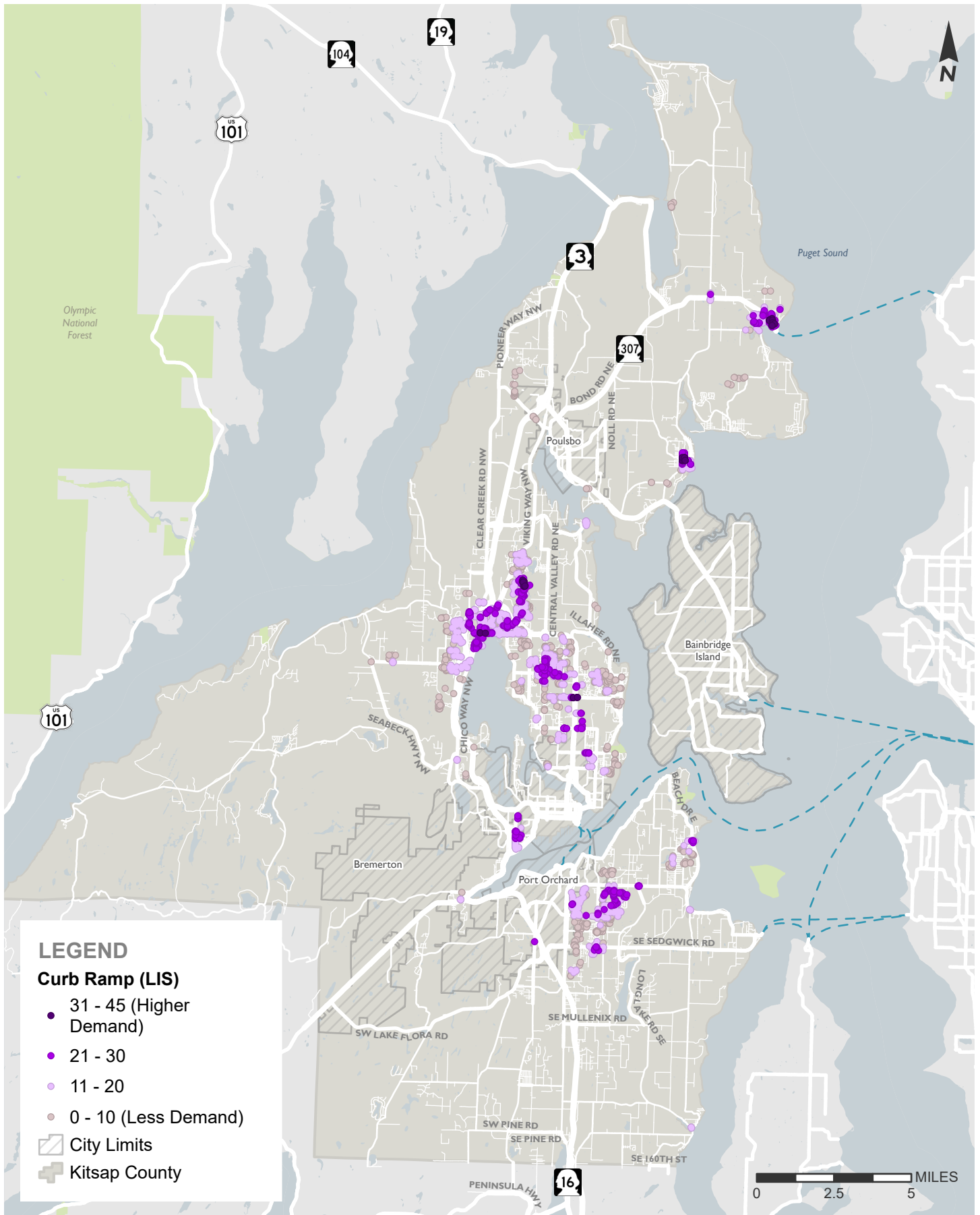

Location Index Score Composite (Curb Ramp)

Kitsap County ADA Transition Plan

DRAFT



FIGURE

4-6

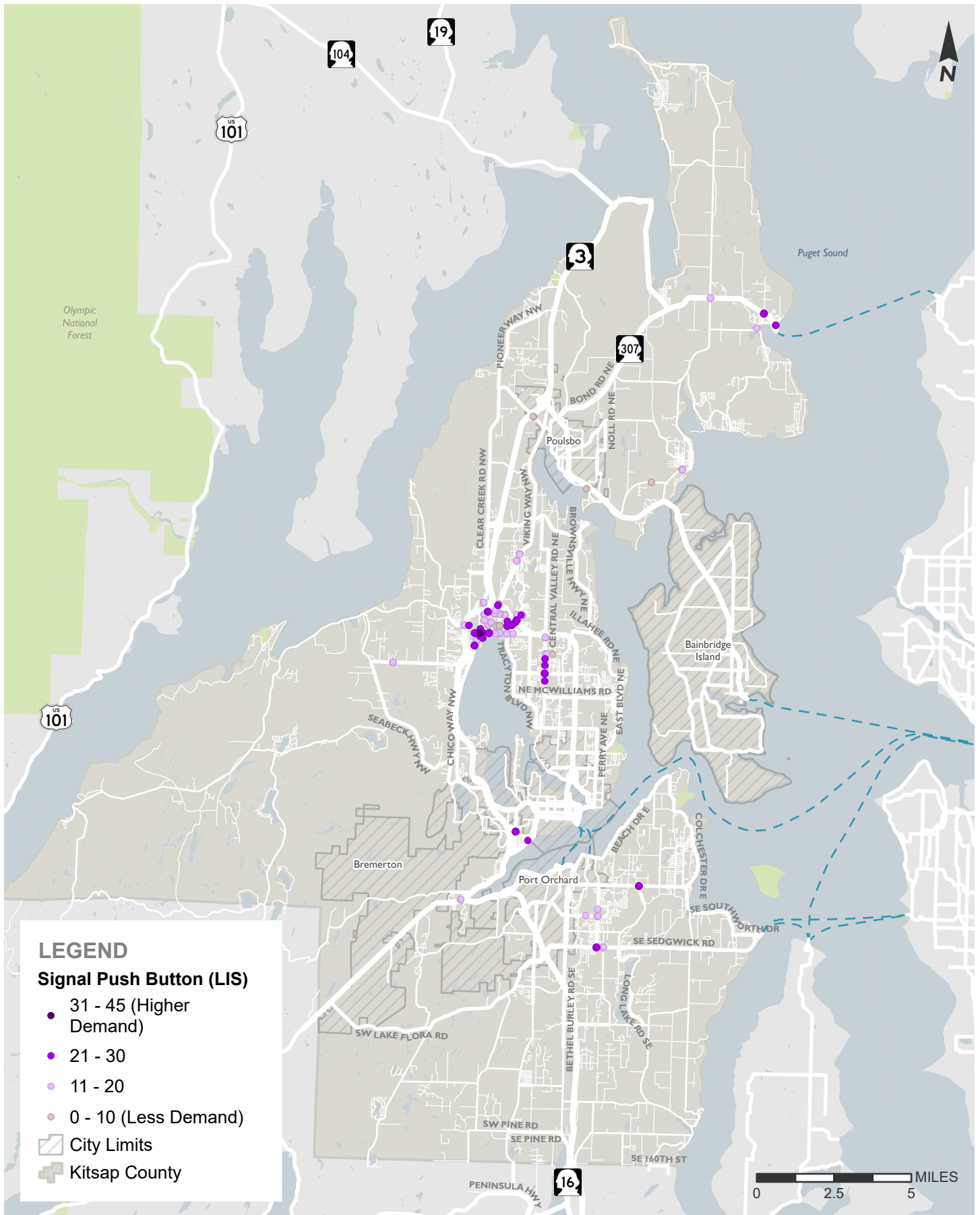

Location Index Score Composite (Signal Push Button)

Kitsap County ADA Transition Plan

DRAFT



FIGURE

4-7

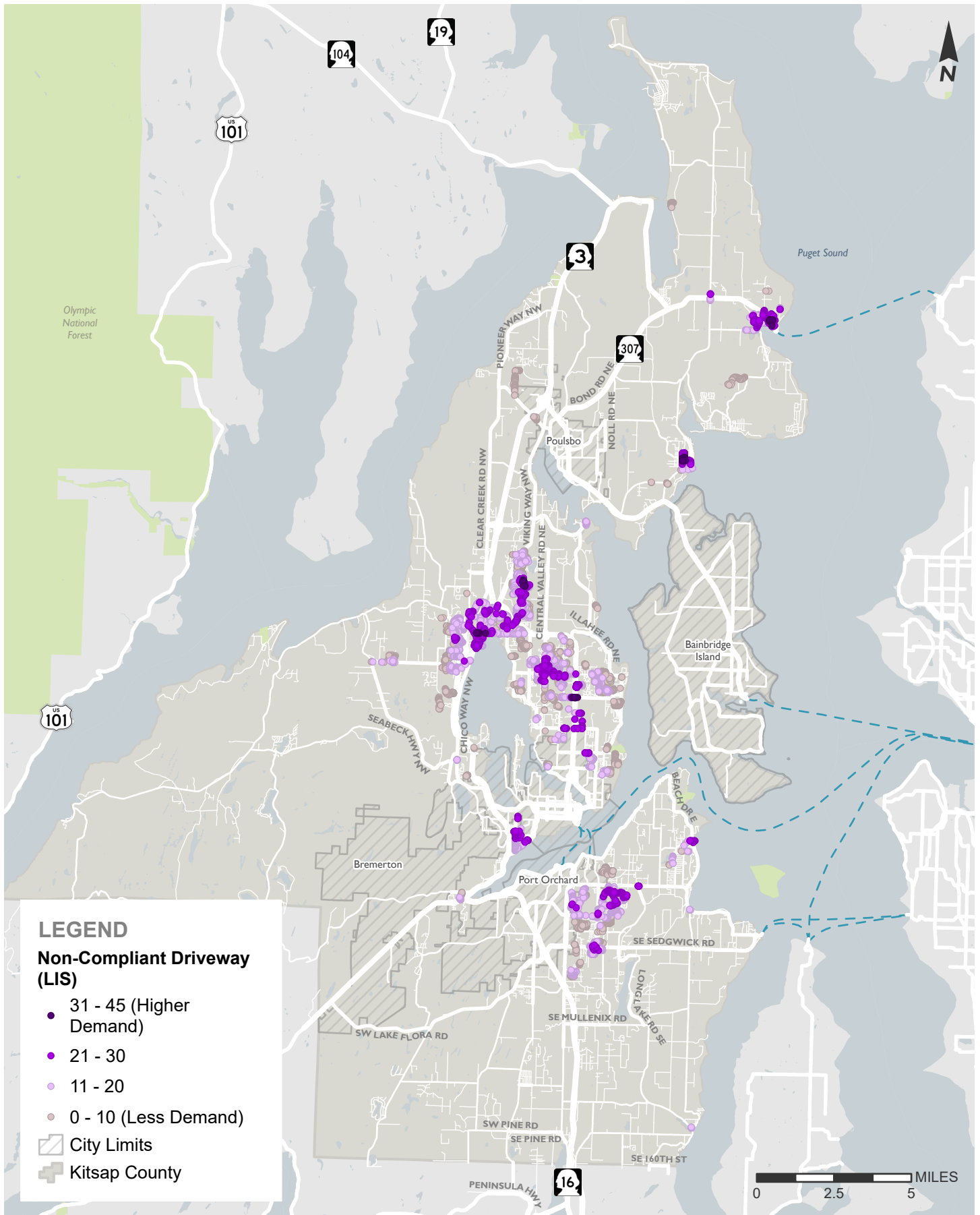

Location Index Score Composite (Non-Compliant Driveway)
 Kitsap County ADA Transition Plan

DRAFT



FIGURE
4-8

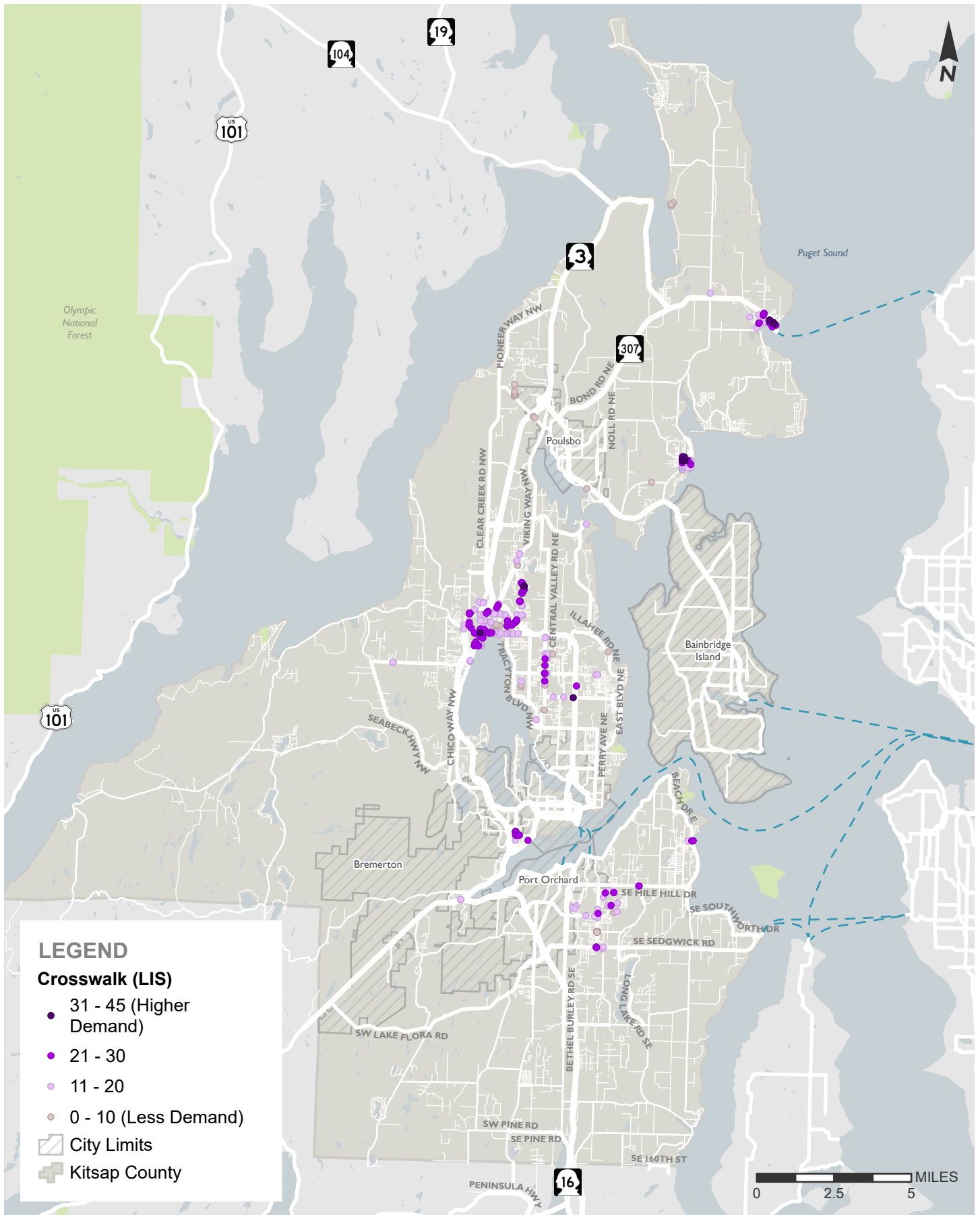

Location Index Score Composite (Crosswalk)

Kitsap County ADA Transition Plan

DRAFT



FIGURE
4-9

Combined Index Score

The Combined Index Score sums the Accessibility Index Score and Location Index Score to prioritize facilities with accessibility barriers in areas where pedestrians would be expected.

Scores were grouped into four categories:

- Very High - significant physical barriers and a high number of hazards in high-demand areas: 46+ points.
- High - significant physical barriers in high-demand areas: 31-45 points.
- Medium - 16-30 points.
- Low - minor barriers in low-demand areas: 1-15 points.

Scores reflect relative priority within each facility type; they do not indicate relative priority between facility types (e.g., the importance of addressing a curb ramp barrier versus a sidewalk barrier).

Combined index scores provide planning level context to barrier removal and overall accessibility needs within the county. As this Transition Plan is implemented, barrier removal will be guided by multiple factors, including funding availability, location of capital projects that include pedestrian elements, construction efficiency, project-level analysis, etc. Barriers of all priority levels will be removed over time.

Figures 4.10 through 4.12 show the combined scores for each of the facilities where data were collected.

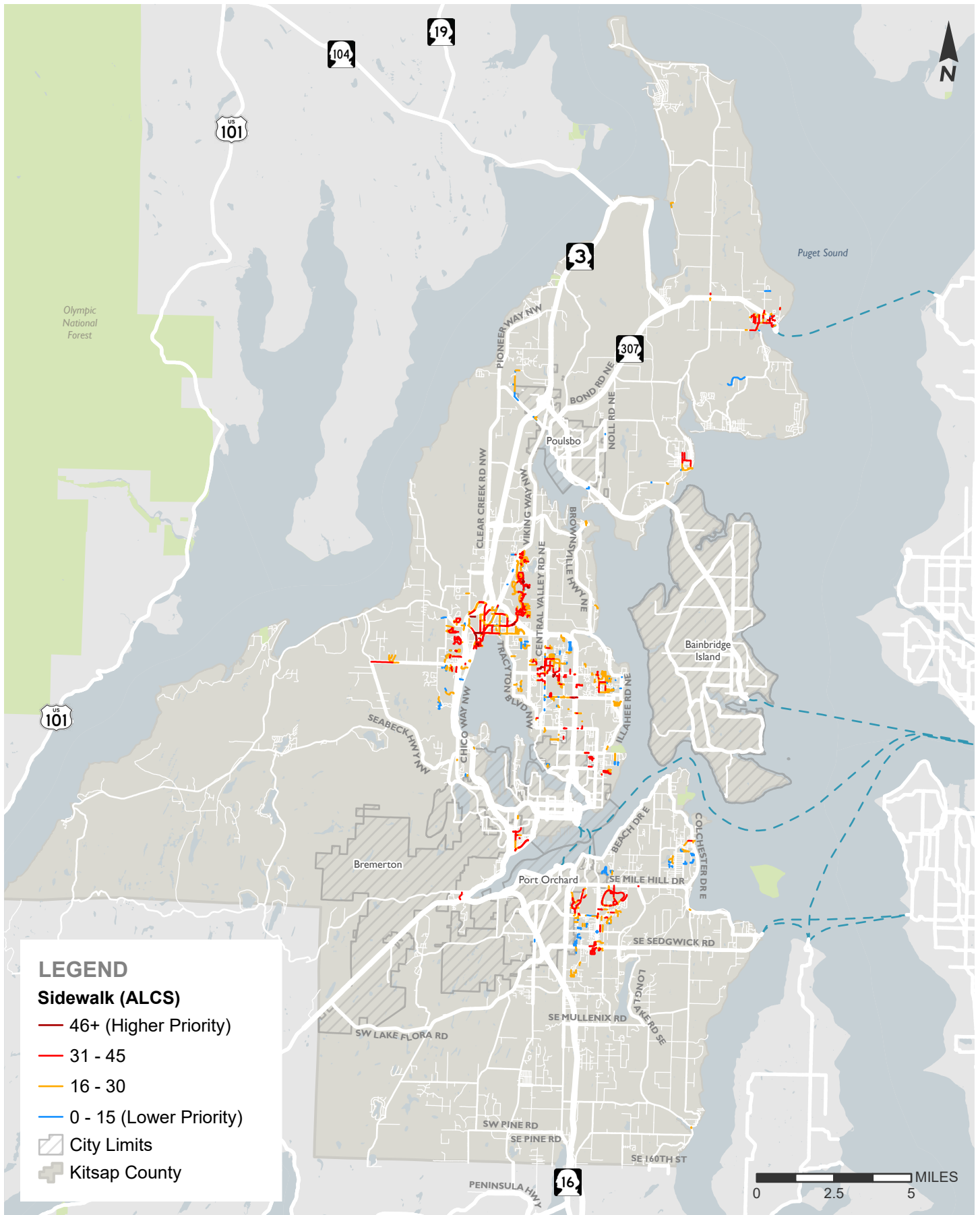

Accessibility (AIS) & Location (LIS) Combined Score (Sidewalk/Pathway)
Kitsap County ADA Transition Plan

DRAFT



FIGURE
4-10

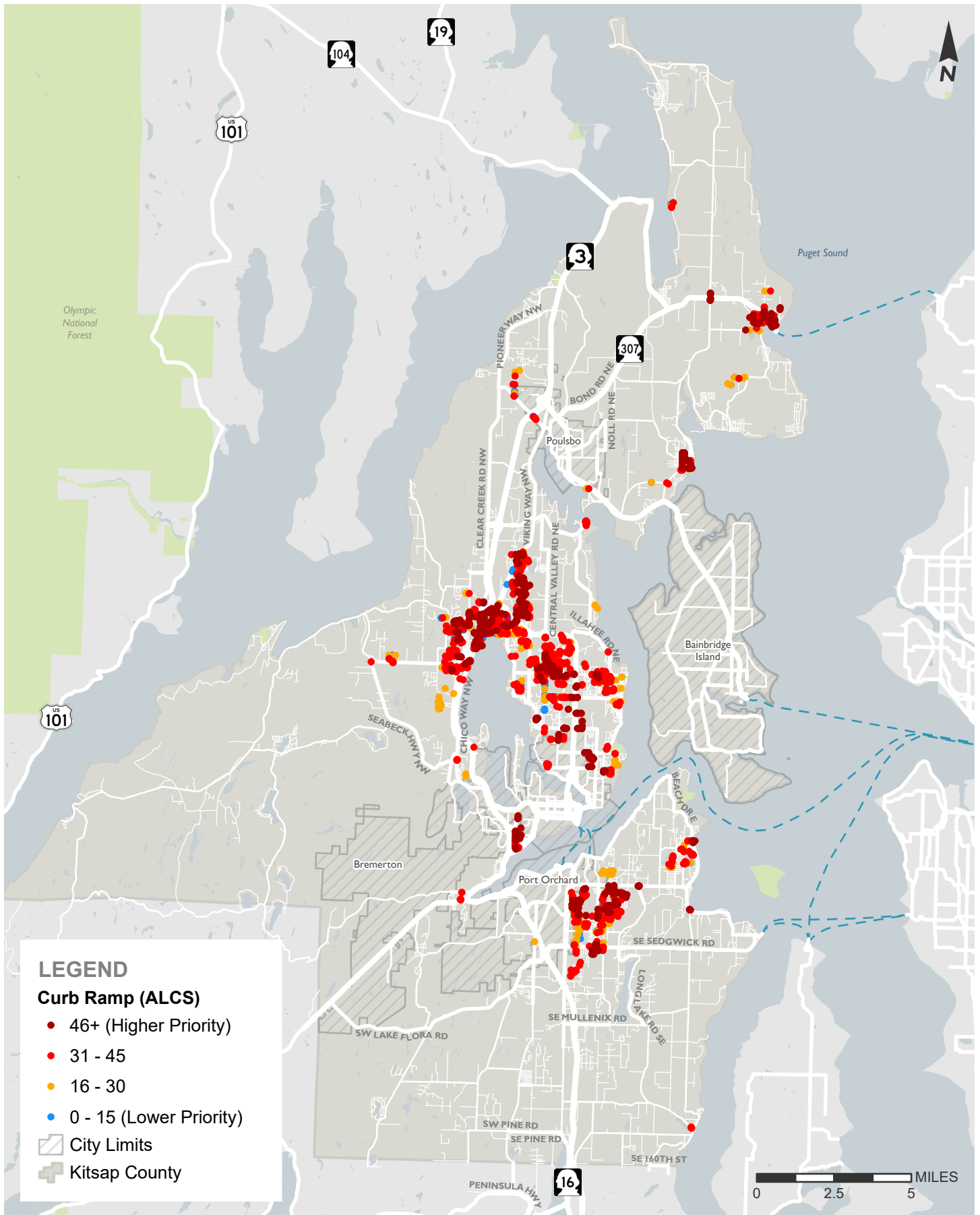

LEGEND

Curb Ramp (ALCS)

- 46+ (Higher Priority)
- 31 - 45
- 16 - 30
- 0 - 15 (Lower Priority)

- ▨ City Limits
- ⊕ Kitsap County



Accessibility (AIS) & Location (LIS) Combined Score (Curb Ramp)

Kitsap County ADA Transition Plan

DRAFT



FIGURE

4-11

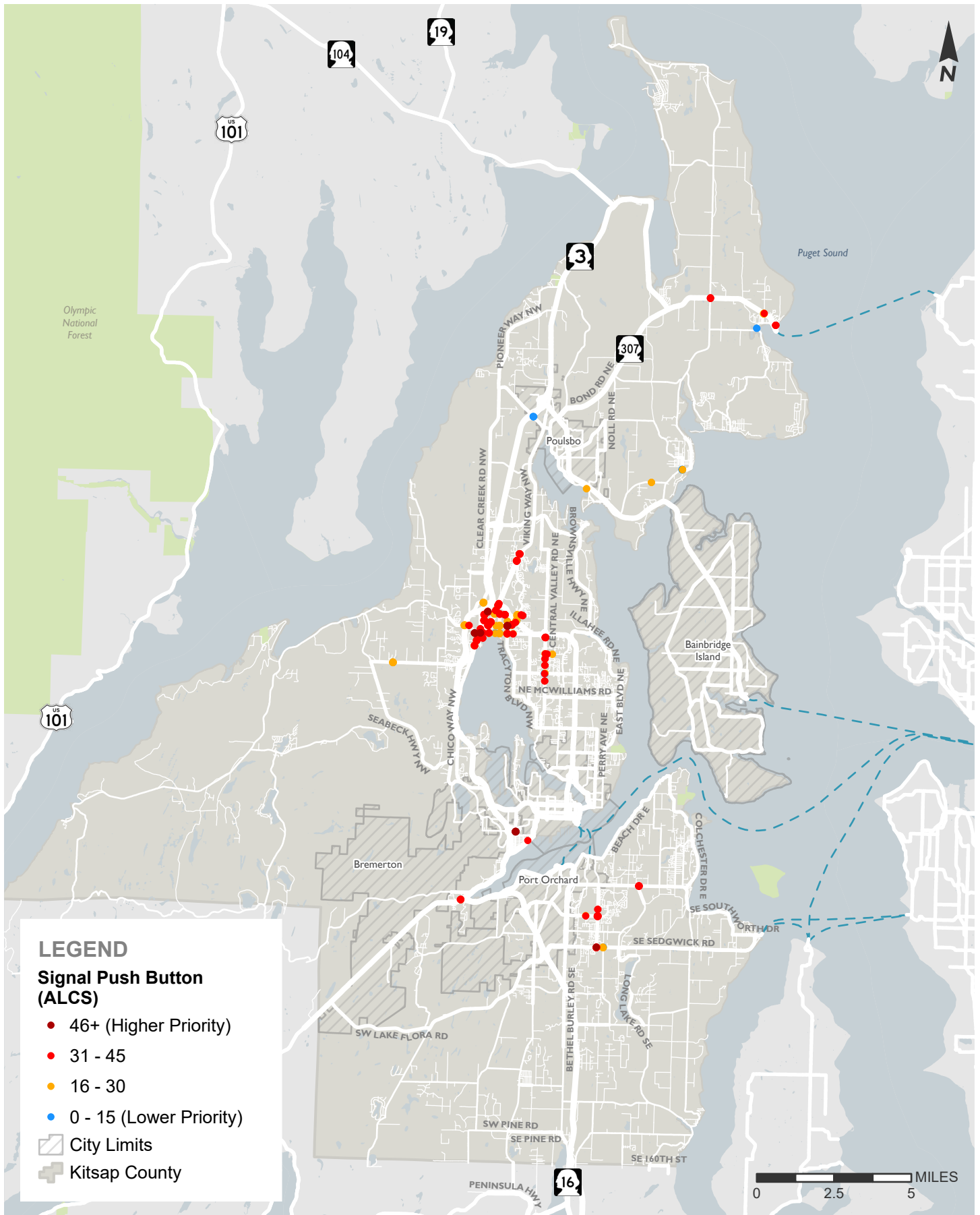

Accessibility (AIS) & Location (LIS) Combined Score (Signal Push Button)
Kitsap County ADA Transition Plan

DRAFT



FIGURE 4-12

4.2.2 Planning Level Cost Estimates to Remove Pedestrian Barriers

To meet the ADA Transition Plan requirement of demonstrating how barriers are to be removed over time, annual available financial resources were estimated and compared to the total estimated barrier removal costs.

Process

Unit costs were developed for the improvements needed to address the pedestrian barriers inventoried through the Self-Evaluation. Unit cost estimates for each barrier type were developed using recent WSDOT and other local construction bid tabulations, input from subject matter experts, and planning level cost assumptions. Unit cost estimates assumed contract-based construction, instead of the use of in-house crews.

Unit cost estimates were applied to the inventoried barriers, with adjustments made to account for construction efficiencies and to avoid applying redundant improvements to the same facility. All cost estimates are in 2024 dollars. Cost estimate assumptions are detailed in Appendix E.

Barrier removal construction cost estimates account for contingency, design, right-of-way, mobilization, temporary erosion control, traffic control, and construction management. Sales tax, structural impacts to buildings, permit fees, inflation, and potential changes to accessibility standards are not assumed in the cost estimate.

This planning level cost analysis did not assess whether non-compliant pedestrian facilities had been built to the maximum extent feasible. Therefore, this cost estimate may overstate the amount of feasible improvements.

The total planning-level cost estimate, or total need, to remove **all identified pedestrian barriers is approximately \$99,113,000** (in 2024 dollars). Cost estimates by facility and improvement type are shown in Table 4.1.

Table 4.1 Planning Level Cost Estimate ROW and On-Site Facilities

ADA DEFICIENCY	IMPROVEMENT TYPES	QUANTITY	UNIT COST	TOTAL COST
Sidewalk Improvements				
Non-compliant sidewalk (width, condition, running slope, cross slope, and/or large vertical discontinuity). ROW	Reconstruct existing sidewalk	189,672 SY	\$145	\$27,502,411
Non-compliant driveway (running slope, cross slope, and/or grade break). ROW	New driveway with sidewalk	1,637 EA	\$2,900	\$4,747,300
Non-compliant sidewalk (width, condition, running slope, cross slope, and/or large vertical discontinuity). On-Site	Reconstruct existing sidewalk	133 SY	\$145	\$19,253
Subtotal				\$32,268,964
Maintenance/Miscellaneous				
Non-compliant vertical discontinuity (>1/4in - <=1/2in w/out bevel). ROW	Sidewalk grinding (5 LF of sidewalk)	2,803 LF	\$250	\$700,750
Non-compliant vertical discontinuity (>1/2in). ROW	Replace two adjacent sidewalk panels (5ft x 5ft panels)	1,444 EA	\$806	\$1,163,222
Non-compliant vertical discontinuity (>1/4in - <=1/2in w/out bevel). On-Site	Sidewalk grinding (5 LF of sidewalk)	4 LF	\$250	\$1,000
Non-compliant vertical discontinuity (>1/2in). On-Site	Replace two adjacent sidewalk panels (5ft x 5ft panels)	1 EA	\$806	\$806
Non-compliant horizontal discontinuity. ROW	Sidewalk crack sealing/ grouting (5LF per occurrence)	23,960 LF	\$5	\$119,800
Non-compliant horizontal discontinuity. On-Site	Sidewalk crack sealing/ grouting (5LF per occurrence)	25 LF	\$5	\$125
Fixed obstacles. ROW	Relocation of obstacles including utility pole, mailbox, tree trunk, etc.	397 EA	\$3,000	\$1,191,000
Moveable obstacles. ROW	Relocation of obstacles including tree/bush (prunable), message boards, parked cars, etc.	1,838 EA	\$200	\$367,600
Moveable obstacles. On-Site	Relocation of obstacles including tree/bush (prunable), message boards, parked cars, etc.	3 EA	\$200	\$600
Protruding obstacles. ROW	Relocation of obstacles including of bush/tree, signs, awnings etc.	841 EA	\$500	\$420,500
Subtotal				\$3,965,403

1/2 (Continued on next page)

Table 4.1 Planning Level Cost Estimate ROW and On-Site Facilities

ADA DEFICIENCY	IMPROVEMENT TYPES	QUANTITY	UNIT COST	TOTAL COST
Curb Ramp Improvements				
Missing curb ramps. ROW	Install new curb ramp	453 EA	\$6,000	\$2,718,000
Missing curb ramps. On-Site	Install new curb ramp	1 EA	\$6,000	\$6,000
Non-compliant curb ramp (width, running slope, cross slope, landing, flare slope, lip, grade break, counter slope, lip, and/or clear space). ROW	Remove and reconstruct existing ramp	1,866 EA	\$6,000	\$11,196,000
Curb ramps without detectable warning surface (DWS), non-compliant DWS placement, non-compliant DWS depth, or non-compliant DWS width. ROW	Install/replace detectable warning surface	90 EA	\$1,030	\$92,700
Curb ramp at marked crosswalk does not end within crosswalk. ROW	Re-channelize crosswalk	7 EA	\$1,100	\$7,700
Subtotal				\$15,368,700
Push Button Improvements				
Non-APS push button and push button is located incorrectly.	Install new APS push button and install new pole	196 EA	\$5,900	\$1,156,400
APS push button that has non-compliant dimensions and/or programming and located incorrectly.	Reprogram push button, reorient push button, and/or install tactile arrow and install new pole and relocated push button	15 EA	\$3,500	\$52,500
APS push button located incorrectly.	Install new pole and relocate push button	40 EA	\$3,700	\$148,000
APS push button that has non-compliant dimensions and/or programming.	Reprogram push button, reorient push button, and/or install tactile arrow	70 EA	\$200	\$14,000
Subtotal				\$1,370,900
Total				\$51,626,000
Contingency @ 20%				\$10,325,200
Design @ 12%				\$6,195,120
Mobilization @ 8%				\$4,130,080
TESC + Traffic Control @ 12%				\$6,191,760
Construction Management @ 20%				\$10,325,200
Right-of-Way @ 20%				\$10,319,600
Grand Total 2024 Dollars				\$99,113,000

2/2 (Table end)

Table 4.2 Funding Allocation by Barrier Priority

INVESTMENT PRIORITY	% FUNDING ALLOCATED TO BARRIER REMOVAL
Very High	40%
High	30%
Medium	20%
Low	10%

4.2.3 Barrier Removal Funding

A requirement of this plan is to forecast available funding that may be used to support plan implementation. This plan assumes total annual funding for barrier removal of \$270,000 per year for pedestrian barrier removal. A breakdown of the annual budget resources anticipated to be available to support pedestrian barrier removal implementation follows.

- Sidewalk Program, \$20,000.
- Upcoming Capital Improvement projects \$6,000.
- Transportation Improvement Program Projects, \$244,000.

See Section 4.1 for details on these programs. These improvements may address low, medium, high, and very high priority barriers, based on the location of a proposed larger project or maintenance program. It was assumed that ADA barrier projects funding

is allocated primarily to very high priority barriers, and the remaining current funding is allocated evenly to low, medium, and high priority barriers.

4.2.4 Schedule

Based upon the Self-Evaluation, planning-level cost estimates, identified barrier removal methods, and projected budgetary resources that may be available, a barrier removal budget and schedule was developed. Due to the extremely large investment needed to remove accessibility barriers, it is important to identify the highest priority barriers and focus resources to remove them first.

An analysis of the barrier prioritization was completed to determine how many barriers found during the Self-Evaluation process are classified as ‘very high’, ‘high’, ‘medium’, and ‘low’ priority, as defined in Section 4.2. Highest priority level represents a significant barrier to accessibility in areas with higher pedestrian demand. Lower priority levels represent less severe barriers to accessibility in areas with lower pedestrian demand. Although some facilities will receive low ratings, all barriers associated with them will still need to be removed or be determined and documented to have been built to accessibility standards to the maximum extent feasible.

The County should aim to remove the highest priority barriers first as targetable funding becomes available. This will support the goal of providing better access to the most needed programs in the shortest timeframe possible.

A Transition Plan schedule was developed to target removal of barriers to accessibility. It was assumed that a greater percentage of current County funding would be allocated to higher priority barriers. Assumed funding allocation based on barrier priority is summarized in Table 4.2. With the County’s current funding, approximately 367 years would be required to remove accessibility barriers of all priorities, **and 105 transition years would be required to remove only the “very high priority” barriers.** An approximately 10 to 20-year plan was developed to estimate the additional annual funding required to remove all very high priority barriers in a shorter frame of time. The Transition Plan is summarized in Table 4.3.

The County should create a two-to-five-year barrier removal plan that outlines how they intend to address the prioritized barriers. The plan should aim to implement a selection of projects each year to remove specific barriers, guided by the data collection and barrier prioritization completed during Self-Evaluation. This plan should continue to focus on the highest priority barriers, as funding allows. The purpose of the repeated plan is to make progress in barrier removal but also to provide a way to reassess the 10- to 20-year plan and measure incremental progress. In order to inform the two-to-five-year plan, a scoping effort should occur that includes site visits for areas identified as highest priority to determine the severity of the barrier and to investigate possible actions to address remaining issues. When selecting projects, site conditions and improvement feasibility should be considered. Areas with multiple barriers within proximity to one another can be grouped together to achieve cost savings. As areas are identified, additional data collection should be completed in the vicinity

Table 4.3 ADA Very High Priority Barrier Removal Transition

TRANSITION YEARS	RECOMMENDED ADDITIONAL ANNUAL INVESTMENT
20 Years	\$300,000
15 Years	\$480,000
10 Years	\$850,000

of the proposed project and added into the facility’s GIS database. This additional information will provide the remaining attributes necessary to determine if a facility fully meets PROWAG requirements.

Following completion of each two to five-year plan implementation cycle, lessons learned regarding costs, methods, schedule, and outcomes shall be evaluated to inform the next two-to-five-year cycle of accessibility barrier removal investments. If progress is slower than anticipated, additional funding may be required. If progress is faster than anticipated, a shorter timeline may be achievable. Several factors may contribute to differences between the estimated transition schedule and the actual rate and cost of implementation. Some of these factors include actual funding acquired, individual project cost, site specific design savings, additional deterioration of pedestrian facilities, and unanticipated capital projects. In addition, it may be determined that some barriers identified through this Transition Plan are on facilities that have been built to the maximum extent feasible, as discussed in Section 5.1. Each project to remove barriers should be evaluated to determine if improvements to the facility are feasible in the engineering design phase.

5 Recommendations and Next Steps

5.1 Recommended Actions

This chapter provides a set of recommendations intended to inform the implementation of this Transition Plan and the ongoing removal of accessibility barriers. Recommendations are not presented in priority order and represent near-term and longer-term Transition Plan implementation workplan tasks.

Recommendations identified as Pending require additional action from the County to implement. Underway recommendations are in progress at this time. On-going recommendations have been previously established and are continually in progress. Complete recommendations have been completed but may require additional action based on adjustments noted in this section.

Recommendation 1:

Update County design standards to match ADA Standards

Status: Pending

A detailed audit of County design standards using Proposed Guidelines for Pedestrian Facilities in the Public Right-of-Way 2023 (PROWAG) was conducted to inform Chapter 2. This audit, which is included in Appendix A, recommends specific changes and additions to the County's standard plans and municipal code. Recommendations were identified for updating existing sidewalk, curb ramp, and push button standards and for filling in ADA guidelines for areas not covered in the County's standards and code. Kitsap County should update these documents to meet PROWAG standards.

Recommendation 2:**Identify an official responsible for Transition Plan implementation within the Public Works Department****Status: Complete**

The County's ADA Coordinator has been identified as the responsible official. This ADA Coordinator position is one of the four major federal requirements for every ADA Transition Plan. The current ADA Coordinator is Tim Perez. The ADA Coordinator is responsible for facilitating transition planning, including activities such as responding to grievance requests. They also function as a central figure for organizing the various programs within the County to maintain a consistent approach to barrier removal and achieving ADA standards across capital, maintenance, and operational activities.

Official Responsible for Plan Implementation:

Tim Perez, Kitsap County ADA Coordinator

Tperez@kitsap.gov

360-337-4675

Recommendation 3:**Develop a Countywide Accessible Pedestrian Signal (APS) policy****Status: Pending**

Accessible Pedestrian Signal (APS) policies serve as a means for jurisdictions to be consistent with ADA requirements at traffic signals. The APS policy covers when installation of APS devices that "communicate information about pedestrian timing in nonvisual formats such as audible tones, verbal messages, and/or vibrating surfaces" (MUTCD) is required. The proposed APS policy is included in Appendix F. It is recommended that this policy be modified to specify that all signalized intersections are required to have APS devices that meet ADA requirements installed.

Recommendation 4:**Educate County staff, consultants, and contractors on ADA standards and provide dedicated training to County inspectors****Status: On-going**

Transition Plans are often a learning experience for County staff, consultants, and contractors alike, since they alter existing practices and expectations. Kitsap County should use updates to the County's Road Standards as an opportunity to teach and learn about accessibility and the barriers that those with impaired mobility experience when traveling in the County's public right-of-way. This should include clarifying guidance from the Department of Justice, for example, that when pedestrian facilities (curb ramps, sidewalks, crosswalks, pedestrian signals, etc.) within the public right-of-way are altered, they must be revised or replaced to meet current ADA standards. Education can take many forms, from review of updated design standards with key individuals such as field inspectors and contractors, ongoing development and review of County specific design standards or checklists with County engineers, or receiving training from groups that serve those with disabilities.

Recommendations 5:

Develop a standard grievance process for barriers to accessibility

Status: Pending

Public entities subject to Title II of the ADA are required to adopt and publish a grievance procedure as part of their Transition Plan. A grievance process allows community members to formally report denial of access to a County facility, program, or activity, on the basis of disability.

Currently, the County has an established process to file a grievance or a request for accommodation or barrier removal during the employment process with the County's Human Resources Director or the County Administrator. A community member can file a grievance or request for accommodation on the County's website by clicking the Equal Employment Opportunity & Disability Accommodation Services link under the "information" icon at the bottom of the Kitsapgov.com web page.

Instructions and contact information are available online for a member of the public to submit a grievance or request for barrier removal. The policy is found in the County's Equal Employment Opportunity & Disability Accommodation Services web page and outlines the grievance procedure and the County staff involved in a grievance request. A grievance will be reviewed by the Human Resources Director or the County Administrator.

The County's grievance procedure can be found in Appendix G.

In addition, Kitsap County has an online form where the public can report concerns of varying types. Street or sidewalk issues are included in this online request form. The form can be found on the [County's Public Works website by visiting the "Report a Problem" tab at the top of the Kitsap County Public Works web page.](#)

The following adjustments are recommended to the County's accommodation request and grievance process:

- Make the grievance process easily navigable from the County's main website. Move to separate ADA section. Clarify that accessibility grievances can also be submitted.
- Provide contact information for the County Administrator, the specified County ADA Coordinator and other relevant County staff on the grievance procedure website.
- Provide information regarding ADA barrier identification and explain how and why a grievance may be accepted or denied by the County.
- Streamline the grievance request process with an online submission option via the County's website, distinct from the general form to report a concern to the County
- Connect the reporting tool used in the public engagement effort for this plan to the request for accommodation web page.
- Provide a timeline for response for filed grievances.

Recommendation 6:**Develop a consistent and centralized MEF documentation database****Status: Ongoing**

The ADA mandates that alterations that could affect the usability of a facility must be made in an accessible manner to the maximum extent feasible (MEF). ADA Standards for Accessible Design (2010) states that:

Each facility or part of a facility altered by, on behalf of, or for the use of a public entity, in a manner that affects or could affect the usability of the facility or part of the facility shall, to the maximum extent feasible, be altered in such manner that the altered portion of the facility is readily accessible to and usable by individuals with disabilities, if the alteration was commenced after January 26, 1992.

The County shall document newly constructed or altered facilities that have been built to the maximum extent feasible, rather than full ADA standards, using standard template. An example of the adopted template, provided by WSDOT, is included in Appendix H. Each project is to be evaluated to determine if improvements to the facility are feasible in the engineering design phase.

The reason for any variation from accessibility standards when it is infeasible to fully remove any barriers should be documented. To help organize MEF documentation, a central location for all MEF documentation can be established and geocoded to the facility location and ensure consistency of data for facilities designed and constructed by others. Consolidation of past MEF records into this data is also recommended.

Recommendation 7:**Develop performance measures and processes to track removal of barriers****Status: Pending**

The primary purpose of an ADA Transition Plan is to develop a timeline and funding strategy for the removal of accessibility barriers. To show progress towards this requirement, the County should develop a process of tracking barrier removal on an annual basis. It is recommended that the County actively update the GIS ADA Self-Evaluation database developed for this plan, tracking how and when ADA barriers are removed. This data can be used to provide two-to-five-year updates on progress and demonstrate to the public as well as federal regulators that the County is making progress to meet Title II requirements. These updates should coincide with the two-to-five-year planning efforts completed to outline future barrier removal efforts.

Recommendation 8:

Look for opportunities to increase existing barrier removal funding

Status: Pending

As stated in Section 4.2.4 and Table 4.2, with the County’s current funding allocation for barrier removal, approximately 105 transition years would be required to remove all very high priority barriers, and an additional annual investment of \$300,000 is required to remove all very high priority barriers within an approximate 20-year transition period.

With the currently available funding, it will take approximately 367 years to remedy accessibility barriers of all priority levels. An additional annual investment of \$1,365,000 per year would be needed to remove all existing barriers to access for people whose travel is impacted by disabilities in Kitsap County within a 60-year time frame. It is recommended that the County actively pursue opportunities to increase annual barrier removal funding.

Appendix A: Standards Review Barrier Audit

TECHNICAL MEMORANDUM

Date:	April 5, 2024	TG:	1.22438.00
To:	Christine DeGeus – Kitsap County		
From:	Patrick Lynch, AICP Transpo Group		
Subject:	Barrier Removal Audit – Kitsap County ADA Transition Plan		

Kitsap County maintains road design standards and municipal code covering pedestrian facilities. The design standards are used for both public and private work performed within the street rights-of-way of Kitsap County. This memorandum describes design guidelines that meet the requirements of the Americans with Disabilities Act (ADA), common accessibility design issues, and references to specific design guidelines. The audit of the City’s roadway design standards and municipal code as they relate to pedestrian features within the public right-of-way include Kitsap County Road Standards 2020 (KCRS) and Kitsap County Code (KCC).

Design Guidelines

There are several key design measurements that ADA design guidelines address. These measures are used because they are important to the accessibility and safety of the facility. When pedestrian facility designs cannot be constructed to full design requirements, they should be built to conform to the maximum extent feasible. When this situation occurs, the County should identify the location where this occurs, provide justification, and document for future reference.

Several guidelines and references are available to assist Kitsap County in adhering to accessible design standards based on the needs for various projects. There are many opportunities to improve pedestrian conditions by identifying areas of need and establishing the appropriate accessibility design requirements.

2010 ADA Standards for Accessible Design (ADAS) (September 2010)

The Department of Justice published revised regulations for Titles II and III of the Americans with Disabilities Act of 1990 “ADA” in the Federal Register on September 15, 2010. These regulations adopted revised, enforceable accessibility standards called the 2010 ADA Standards for Accessible Design “2010 ADAS”. The 2010 Standards set minimum requirements – both scoping and technical – for newly designed and constructed or altered State and local government facilities, public accommodations, and commercial facilities to be readily accessible to and usable by individuals with disabilities.

Proposed Guidelines for Pedestrian Facilities in the Public Right-of Way (PROWAG) (August 2023)

The United States Access Board is the rule making body that guides ADA compliance across the US. Since the late 2000’s the US Access Board has been in the process of updating its Guidelines for Pedestrian Facilities in the Public Rights-of-Way. These draft guidelines focus on accessibility of sidewalks, curb ramps and, in the recently released versions, address shared-use trails. The draft guidelines cover legislative background, administration requirements, and design requirements.

Many public entities currently use the 2005 draft PROWAG as ‘best practice’ for features within the public right-of-ways. This practice has been endorsed by the Federal Highway Administration (FHWA), the US Access Board, and is the standard the Washington Department of Transportation adheres to. The County’s standards and codes were evaluated against 2023 PROWAG, as this is the latest guideline developed by the Access Board. PROWAG sections referenced in this memo refer to 2023 PROWAG sections. When these standards conflict with the 2010 ADAS, the PROWAG standard is recommended.

Design Requirements and Recommendations

Although Kitsap County has standards in place, it is important for the standards to be consistent and compliant with the previously described standards and guidelines. To that end, this memo will provide recommendations to improve and clarify the existing County documents. Additionally, recommended actions are included where necessary to meet ADA design standards and best practice. The following tables describe requirements for specific design elements, how they are addressed in County standards, and recommendations for modifications.

The KCRS provides references to other regulations and specifications that all road plans shall be consistent with (in addition to the County standards and ordinances, and Kitsap County Code).

“The most current edition as amended of the following publications and manuals shall be applicable when specifically cited in the Standards or when required by state or federal funding authorities.

1. A Policy on Geometric Design of Highways and Streets, American Association of State Highway and Transportation Officials (AASHTO), as amended and approved by WSDOT (commonly referred to as the “Green Book” in these Standards)
2. Standard Specifications for Road, Bridge and Municipal Construction, Washington State Department of Transportation (WSDOT) and American Public Works Association (APWA)
3. Standard Plans for Road, Bridge and Municipal Construction, WSDOT and APWA
4. WSDOT Design Manual
5. Local Agency Guidelines, WSDOT
6. Guidelines for Geometric Design of Very Low-Volume Local Roads (ADT less than or equal to 400), AASHTO
7. Roadside Design Guide, AASHTO
8. Manual on Uniform Traffic Control Devices (MUTCD), Federal Highway Administration (FHWA), as amended and approved by WSDOT
9. Construction Manual, WSDOT
10. Guide for the Development of Bicycle Facilities, AASHTO
11. Guide for the Planning, Design, and Operation of Pedestrian Facilities, AASHTO
12. Traffic Manual, WSDOT
13. Highway Capacity Manual, Transportation Research Board
14. Trip Generation Manual, Institute of Transportation Engineers
15. Bridge Design Manual, WSDOT”

(KCRS Section 1.3)

Sidewalks and Pathways

Sidewalks are mentioned in the County’s standard details and county code. These standards cover desired dimensions and materials to be used for construction of these facilities. Sidewalks are a common element found in a pedestrian access route (PAR).

Design Element	Requirement	Review	Recommendations
Pedestrian Access Route (PAR) & Connection to Accessible Facilities	Accessible elements, spaces, and pedestrian facilities are required to be accessible and connect to accessible routes.	<p>“Where sidewalks are required, sidewalk and curb ramps shall meet the requirements of the Americans with Disabilities Act (ADA).” (KCRS Section 3.7.5.1)</p> <p>“Sidewalk design shall be consistent with all the requirements of the Kitsap County road standards.”(KCC Section 17.420.037. A. 1)</p>	N/A
Sidewalk Width	<p>Minimum clear width of PAR is 48 inches excluding the curb; however, on PAR less than 60 inches wide, passing space of 60 inches by 60 inches minimum is required every 200 feet minimum. (PROWAG R302.2 and R302.3)</p> <p>The clear width of walking surfaces shall be 36 inches minimum. The clear width shall be permitted to be reduced to 32 inches minimum for a length of 24 inches maximum, provided that reduced width segments are separated by segments that are 48 inches long minimum and 36 inches wide minimum. Additional space is required at turns (ADAS 403.5.1).</p>	<p>Sidewalk width is based on Roadway Classifications:</p> <p>Local Sub-collector Urban – 5ft</p> <p>Local Road Urban – 5ft</p> <p>Principle Arterial – 6ft</p> <p>Minor Arterial – 6ft</p> <p>Collector – 6ft</p> <p>(KCRS Section 3.7 Tables 3-3 and 3-4)</p>	N/A
Sidewalk Running Slope	<p>When the PAR is contained within highway right-of-way, the grade shall not exceed 1:20 (5.0 percent). With the exception of where the grade established for the adjacent street exceeds 1:20 (5.0 percent), the grade of the PAR shall not exceed the grade established for the adjacent street (PROWAG R302.4.1).</p> <p>The running slope of walking surfaces shall not be steeper than 1:20 (ADAS 403.3).</p>	<p>“When sidewalk is adjacent to a roadway, then the slope is allowed to match the profile of the road.” (KCRS Standard Detail Figure 4-3)</p>	<p>Add/revise a note on KCRS Figures 4-3, 4-4, and 4-5 the running slope for a sidewalk along the roadway shall not exceed the general grade of the roadway. Sidewalks not adjacent to a roadway shall not have a running slope greater than 5%.</p>
Sidewalk Cross Slope	<p>The cross slope of a PAR not contained within a crosswalk shall be 1:48 (2.1 percent) maximum. Excepting for the portion of a PAR within a street that connects an accessible parallel on-street parking space to the nearest crosswalk at the end of a midblock crosswalk is not required to comply with R302.5 (PROWAG R302.5.1)</p>	<p>Sidewalk cross slope is shown as 2% (KCRS Figures 3-1 and 4-4).</p>	<p>Recommend including a desired cross slope of 1.5% or flatter to allow for construction tolerances with 2% as the maximum cross slope.</p>

Sidewalks and Pathways

Design Element	Requirement	Review	Recommendations
Protruding Objects	<p>The cross slope of walking surfaces shall not be steeper than 1:48 (ADAS 403.3).</p> <p>Objects with leading edges more than 27 inches and less than 80 inches above the walking surface shall not protrude more than 4 inches maximum horizontally into the pedestrian circulation path (PCP). Exception: Handrails shall be permitted to protrude to 4.5 inches maximum (PROWAG R402.2 & ADAS 307.2).</p> <p>Objects mounted on free-standing posts or pylons more than 27 inches and less than 80 inches above the walking surface shall not protrude into the PCP more than 4 inches maximum, measured horizontally from the post or pylon base. The base dimension shall be 2.5 inches thick minimum (PROWAG R402.3.1).</p> <p>Where objects are mounted between posts or pylons and the clear distance between the posts or pylons is greater than 12 inches, the lowest edge of the object shall be 27 inches maximum or 80 inches minimum above the walking surface. Exception: when a barrier with its lowest edge at 27 inches is provided between the posts or pylons (PROWAG R402.3.2).</p> <p>Free-standing objects mounted on posts or pylons shall overhang circulation paths 12 inches maximum when located 27 inches minimum and 80 inches maximum above the finish floor or ground. Where a sign or other obstruction is mounted between posts or pylons and the clear distance between the posts or pylons is greater than 12 inches, the lowest edge of such sign or obstruction shall be 27 inches maximum or 80 inches minimum above the finish floor or ground (ADAS 307.3).</p>	<p>Refers to other standard publications for items not covered in the standards (KCRS Section 1.3).</p> <p>"An abutter shall keep abutting sidewalks free of snow, ice, structures, obstructions, grease, oil and vegetation." JKCC Section 9.28.020)</p>	N/A

Sidewalks and Pathways

Design Element	Requirement	Review	Recommendations
Surface Discontinuities	<p>Vertical surface discontinuities 0.25 inches maximum shall be permitted. Vertical discontinuities between 0.25 inches and 0.5 inches maximum shall be beveled not steeper than 1:2 (50 percent). Changes in level greater than 0.5 inches up to 6 inches shall have an 1:12 (8.3 percent) maximum slope. Changes to a level greater than 6 inches shall comply to PROWAG R407 (PROWAG R302.6.2).</p> <p>Horizontal openings shall not allow passage of a sphere more than 0.5 inches in diameter. Except where multiple directions of travel intersect, elongated openings in grates shall be placed so that the long dimension is perpendicular to the dominate travel direction (PROWAG R302.7.3).</p> <p>Vertical changes in level of 0.25 inch maximum shall be permitted to be vertical. Changes in level between 0.25 inch minimum and 0.5 inch maximum shall be beveled with a slope not steeper than 1:2 (50 percent) (ADAS 302.2 & 302.3).</p>	<p>Refers to other standard publications for items not covered in the standards (KCRS Section 1.3).</p>	<p>N/A</p>

Crossings

Crosswalks are part of the PAR at intersections, midblock crossings, and pedestrian refuge islands. These are important connections across streets to enable pedestrians travelling from one side to the other.

Design Element	Requirement	Review	Recommendations
Crosswalk Running Slope	The running slope shall be 1:20 (5 percent) maximum, measured parallel to the direction of pedestrian travel in the crossing. Except where roadway design requires superelevation greater than 1:20 (5 percent) at the location of the crosswalk, the grade of the crosswalk may be the same as the superelevation (PROWAG R302.4.3).	Not mentioned.	Add running slope requirements to KCRS Figure 5-2.
Crosswalk Cross Slope	<p>Crosswalk cross slope at yield or stop control crossings shall be 1:48 (2.1 percent) maximum (PROWAG R305.2.1).</p> <p>Crosswalk cross slope at uncontrolled crossings shall be 1:20 (5.0 percent) maximum (PROWAG R302.5.2.2).</p> <p>Crosswalk cross slope at a traffic control signal or pedestrian hybrid beacon shall be 1:20 (5 percent) maximum (PROWAG R302.5.2.3).</p> <p>Crosswalk cross slope at midblock crossings shall not exceed the street grade (PROWAG R302.5.2.4).</p>	Not mentioned.	Add cross slope requirements for different situations to KCRS Figure 5-2.
Refuge Islands	<p>Detectable warning surfaces at cut-through pedestrian refuge islands shall be located no greater than 6 inches from the edges of the pedestrian refuge island or at back of curb and be separated by a 24 inches minimum length of surface between detectable warning surfaces (PROWAG R305.2.4).</p> <p>The clear width of a PAR within a median and pedestrian refuge islands shall be 60 inches minimum. Except where a shared use path crosses a median and pedestrian refuge island, they shall be a minimum of 60 inches or at least as wide as the crosswalk, whichever is greater (PROWAG R302.2.1).</p>	Refers to other standard publications for items not covered in the standards (KCRS Section 1.3).	N/A

Curb Ramps

Curb ramps are the immediate junctions between the sidewalk and street crosswalk. Perpendicular and diagonal curb ramps have a running slope that cuts through the curb at right angles, while parallel curb ramps have a running slope that is in-line with the sidewalk. Combination ramps include elements of both parallel and perpendicular curb ramps.

Design Element	Requirement	Review	Recommendations
Ramp Width	<p>The clear width of curb ramp runs and blended transitions, excluding flares, shall be 48 inches minimum. The clear width of curb ramp runs on a shared use path shall be equal to the width of the shared use path (PROWAG R304.5.1).</p> <p>The clear width of a ramp run shall be 36 inches minimum (ADAS 405.5).</p>	<p>"Curb ramps shall meet the requirements of the Americans with Disabilities Act (ADA)." (KRCS Section 3.7.5.1).</p> <p>Refers to other standard publications for items not covered in the standards (KCRS Section 1.3).</p>	N/A
Running Slope	<p>The running slope shall be 1:12 (8.3 percent) maximum but shall not require the ramp length to exceed 15.0 feet (PROWAG R304.2.1 and R304.3.1).</p> <p>The running slope of blended transitions shall be 1:20 (5.0 percent) maximum (PROWAG R304.4.1).</p> <p>Ramp runs shall have a running slope not steeper than 1:12. In existing sites, buildings, and facilities, ramps shall be permitted to have running slopes steeper than 1:12 complying with Table 405.2 where such slopes are necessary due to space limitations (ADAS 405.2).</p>	<p>"Curb ramps shall meet the requirements of the Americans with Disabilities Act (ADA)." (KRCS Section 3.7.5.1).</p> <p>Refers to other standard publications for items not covered in the standards (KCRS Section 1.3).</p>	N/A
Cross Slope	<p>The cross slope for perpendicular curb ramps shall be 1:48 (2.1 percent) maximum but are permitted to be equal or less than the cross slope of the crosswalk. (PROWAG R304.2.2).</p> <p>The cross slope for parallel curb ramps shall be 1:48 (2.1 percent) maximum (PROWAG R304.3.2).</p> <p>The cross slope for blended transitions shall be equal to or less than the cross slope of the crosswalk (PROWAG R304.4.2).</p> <p>Cross slope of ramp runs shall not be steeper than 1:48 (2.1 percent) (ADAS 405.3).</p>	<p>"Curb ramps shall meet the requirements of the Americans with Disabilities Act (ADA)." (KRCS Section 3.7.5.1).</p> <p>Refers to other standard publications for items not covered in the standards (KCRS Section 1.3).</p>	N/A

Curb Ramps

Design Element	Requirement	Review	Recommendations
Flared Sides	<p>Flared sides shall have a slope of 1:10 (10.0 percent) maximum, measured parallel to the curb line, shall be provided where a pedestrian circulation path crosses the side of the curb ramp (PROWAG R304.2.6).</p> <p>Curb ramp flares shall not be steeper than 10 percent (ADAS 406.3).</p>	<p>“Curb ramps shall meet the requirements of the Americans with Disabilities Act (ADA).” (KRCS Section 3.7.5.1).</p> <p>Refers to other standard publications for items not covered in the standards (KRCS Section 1.3).</p>	N/A
Direction	<p>Perpendicular curb ramps shall have a running slope that is perpendicular to the curb or gutter grade break (PROWAG R304.2.1).</p> <p>Parallel curb ramps shall have a running slope that is parallel to the curb (PROWAG R304.3.1).</p>	<p>“Curb ramps shall meet the requirements of the Americans with Disabilities Act (ADA).” (KRCS Section 3.7.5.1).</p> <p>Refers to other standard publications for items not covered in the standards (KRCS Section 1.3).</p>	N/A
Change of Grade	<p>The counter slope of the gutter or street at the foot of curb ramp run, blended transitions, and turning space shall be based off either two conditions:</p> <ul style="list-style-type: none"> A. The change of grade shall not exceed 13.3 percent. B. A transitional space is provided at the bottom of the running slope of the curb ramp run or blended transition. The transitional space shall extend 24 inches minimum in the direction of pedestrian travel and the full width of the curb ramp/blended transition. Transitional space will have a running slope of 1:48 or 2.1 percent maximum. <p>(PROWAG R304.5.2)</p> <p>Counter slopes of adjoining gutters and road surfaces immediately adjacent to the curb ramp shall not be steeper than 5 percent. The adjacent surfaces at transitions at curb ramps to walks, gutters, and streets shall be at the same level (ADAS 406.2).</p>	<p>“Curb ramps shall meet the requirements of the Americans with Disabilities Act (ADA).” (KRCS Section 3.7.5.1).</p> <p>Refers to other standard publications for items not covered in the standards (KRCS Section 1.3).</p>	N/A

Curb Ramps

Design Element	Requirement	Review	Recommendations
Grade Breaks	<p>Grade breaks at the top and bottom of curb ramps shall be perpendicular to the direction of ramp run. Grade breaks shall not be permitted on the surface of ramp runs and turning spaces. Surface slopes that meet at grade breaks shall be flush (PROWAG R304.3.3).</p> <p>Changes in level other than the running slope and cross slope are not permitted on ramp runs (ADAS 405.4).</p>	<p>"Curb ramps shall meet the requirements of the Americans with Disabilities Act (ADA)." (KRCS Section 3.7.5.1).</p> <p>Refers to other standard publications for items not covered in the standards (KCRS Section 1.3).</p>	N/A
Landing Size	<p>For perpendicular curb ramps, the landing shall be 48 inches by 48 inches minimum and be provided at the top of the curb ramp. At shared used paths, the landing shall be as wide as the shared used path. (PROWAG R304.2.5).</p> <p>For parallel curb ramps, the landing shall be 48 inches by 48 inches minimum shall and be provided at the bottom of the curb ramp. (PROWAG R304.3.4)</p> <p>The landing clear length shall be 36 inches minimum. The landing clear width shall be at least as wide as the curb ramp, excluding flared sides, leading to the landing (ADAS 406.4).</p>	<p>"Curb ramps shall meet the requirements of the Americans with Disabilities Act (ADA)." (KRCS Section 3.7.5.1).</p> <p>Refers to other standard publications for items not covered in the standards (KCRS Section 1.3).</p>	N/A
Landing Slope	<p>For perpendicular curb ramp landings that serve one curb ramp, the landing slope measured perpendicular to the curb ramp run shall be equal to or less than the cross slope of the ramp run. The landing slope measured parallel to the curb ramp run shall be 1:48 (2.1 percent) maximum. (PROWAG R304.2.5).</p> <p>For perpendicular curb ramp landings that serve two curb ramps, the landing slope in either direction of travel shall not exceed the cross slope of the crosswalk that is parallel to the direction of travel. (PROWAG R304.2.5).</p> <p>For parallel curb ramps, the slope of the landing measured parallel to the direction of travel of the curb ramp run, shall be equal to or less than the cross slope of the crosswalk. The cross slope of the landing shall be 1:48 (2.1 percent) maximum measured perpendicular to the direction of travel of the curb ramp run (PROWAG R304.3.4).</p>	<p>"Curb ramps shall meet the requirements of the Americans with Disabilities Act (ADA)." (KRCS Section 3.7.5.1).</p> <p>Refers to other standard publications for items not covered in the standards (KCRS Section 1.3).</p>	N/A

Curb Ramps

Design Element	Requirement	Review	Recommendations
Clear Area	<p>Beyond the bottom grade break for perpendicular ramps, a clear area, 48 inches by 48 inches minimum, shall be provided within the width of the crosswalk. At shared use paths, the clear area shall be as wide as the shared use path. The clear area shall be located wholly outside of the vehicle travel lanes, including bicycle lanes, that run parallel to the crosswalk. The running slope of the clear area shall be 1:20 (5.0 percent) maximum (PROWAG R304.2.4).</p> <p>Diagonal or corner type curb ramps with returned curbs or other well-defined edges shall have the edges parallel to the direction of pedestrian flow. The bottom of diagonal curb ramps shall have a clear space 48 inches minimum outside active traffic lanes of the roadway. Diagonal curb ramps provided at marked crossings shall provide the 48 inches minimum clear space within the markings. Diagonal curb ramps with flared sides shall have a segment of curb 24 inches long minimum located on each side of the curb ramp and within the marked crossing (ADAS 406.6).</p>	<p>"Curb ramps shall meet the requirements of the Americans with Disabilities Act (ADA)." (KRCS Section 3.7.5.1).</p> <p>Refers to other standard publications for items not covered in the standards (KRCS Section 1.3).</p>	N/A
Detectable Warning Surfaces	<p>Detectable warning surfaces shall extend 24 inches minimum in the direction of pedestrian travel and the full width of the curb ramp (exclusive of flares), blended transition, or landing (PROWAG R305.1.4).</p> <p>The truncated domes in a detectable warning surface shall have a base diameter of 0.9 inches minimum and 1.4 inches maximum, a top diameter of 50 percent of the base diameter minimum and 65 percent of the base diameter maximum, and a height of 0.2 inches (PROWAG R305.1.1 & ADAS 705.1.1).</p> <p>The truncated domes shall have a center-to-center spacing of 1.6 inches minimum and 2.4 inches maximum, and a base-to-base spacing of 0.65 inches minimum, measured between the most adjacent domes (PROWAG R305.1.2 & ADAS 705.1.2)</p> <p>Detectable warning surfaces shall contrast visually with adjacent walking surfaces either light-on-dark, or dark-on-light (PROWAG R305.1.3 & ADAS 705.1.3).</p>	<p>"Curb ramps shall meet the requirements of the Americans with Disabilities Act (ADA)." (KRCS Section 3.7.5.1).</p> <p>Refers to other standard publications for items not covered in the standards (KRCS Section 1.3).</p>	N/A

Curb Ramps

Design Element	Requirement	Review	Recommendations
Detectable Warning Surface Placement	<p>On perpendicular curb ramps, detectable warning surfaces shall be placed as follows:</p> <ul style="list-style-type: none"> • Where the ends of the bottom grade break are in front of the back of curb or edge of pavement if there is no curb, the detectable warning surface shall be placed at the back of curb or no greater than 6 inches from the edge of pavement where there is no curb. • Where the ends of the bottom grade break are behind the back of curb or edge of pavement if there is no curb and the distance from either end of the bottom grade brake to the back of curb is 60 inches or less, the detectable warning surfaces shall be placed on the ramp run at the bottom grade break. • Where the ends of the bottom grade break are behind the back of curb or edge of pavement if there is no curb and the distance from either end of the bottom grade brake to the back of curb is more than 60 inches, the detectable warning surfaces shall be placed on the clear area so that both front corners of the detectable warning surfaces are at the back of curb, or no greater than 6 inches from of edge of pavement if there is no curb. <p>(PROWAG R305.2.1).</p> <p>On parallel curb ramps, detectable warning surfaces shall be placed on the landing at either the back of curb or edge of pavement where there is no curb (PROWAG R305.2.2).</p> <p>On blended transitions, detectable warning surface shall be located on the blended transition so that both front corners of the detectable warning surface are at the back of curb or no greater than 6 inches from the edge of pavement where there is no curb (PROWAG R305.2.3).</p> <p>Where a concrete border is required for installation of the detectable warning surface, a concrete border shall not exceed 2 inches (PROWAG R305.2)</p>	<p>"Curb ramps shall meet the requirements of the Americans with Disabilities Act (ADA)." (KRCS Section 3.7.5.1).</p> <p>Refers to other standard publications for items not covered in the standards (KRCS Section 1.3).</p>	<p>N/A</p>

Curb Ramps

Design Element	Requirement	Review	Recommendations
Receiving Ramp	A crosswalk served by a curb ramp must also have an existing curb ramp in place on the receiving end unless there is no curb or sidewalk on that end of the crosswalk Revised Code of Washington (RCW) 35.68.075.	"Separate curb ramps shall be provided for each direction of permitted pedestrian travel" (KRCS Section 3.7.5.1).	N/A

Signals

Signals are important connections in the pedestrian network that provide crossings at intersections for all roadway users. Where pedestrian signals are provided at pedestrian street crossings, they shall include accessible pedestrian signals and pedestrian push buttons complying with sections 4E.08 through 4E.13 of the MUTCD (PROWAG R209.1). Kitsap County Road Standards has the following section that covers what standards traffic signal systems within the County should be designed to:

"When designing traffic signal systems for the County, the design shall be in accordance with the National Electrical Code, conform to all the pertinent requirements of these Standards, policies, and directives, and utilize the standards and practices outlined in the current or amended editions of the following publications:

1. MUTCD
2. WSDOT Design Manual
3. WSDOT Traffic Manual
4. WSDOT/APWA Standard Specifications"

(KCRS Section 5.3).

Design Element	Requirement	Review	Recommendations
Accessible Pedestrian Signals and Pedestrian Push buttons	Where pedestrian signal heads and pedestrian activated warning devices are provided, the accessible features required by the guidelines shall be available at all times (PROWAG R206.1). Where pedestrian signal heads are provided at crosswalks, the walk indication shall comply with R308. Pedestrian signal heads must have a pedestrian push button complying with R307, except for R307.7, or passive detection or pretimed operation that activates audible and vibrotactile indications complying with R308. (PROWAG R206.2).	"Pedestrian activity shall be considered at all traffic signal installations. For each pedestrian crossing, a pedestrian push button assembly and Accessible Pedestrian Signals shall be provided. In consideration of the Americans with Disabilities Act (ADA) requirements, curb ramps shall be constructed on or near the crosswalks at intersections" (KCRS Section 5.3.2).	N/A
Location	Push buttons shall be located no greater than 5 feet from the side of a curb ramp or the edge of the farthest associated crosswalk line from the center of the intersection. Push buttons shall be located between 1.5 and 10 feet from the edge of the curb (PROWAG R307.4).	Refers to other standard publications for items not covered in the standards (KCRS Section 5.3).	N/A
Orientation	The face of the push buttons shall be parallel to its associated crosswalk (PROWAG 307.5).	Refers to other standard publications for items not covered in the standards (KCRS Section 5.3).	N/A
Audible and Vibrotactile Walk Indications	Push buttons or passive detection devices shall activate audible and vibrotactile walk indications. Push buttons or a passive detective device for a pedestrian activated warning device (i.e., RRFB), shall activate a speech message that indicates the status of the beacon. It shall not include vibrotactile features indicating walk interval (PROWAG 307.6).	Refers to other standard publications for items not covered in the standards (KCRS Section 5.3).	N/A

Signals

Design Element	Requirement	Review	Recommendations
	<p>Audible and vibrotactile walk indication shall occur in the walk interval only. It should be audible from the beginning of the crosswalk (PROWAG R308.2).</p> <p>A percussive tone shall be used for areas with a signal pedestrian signal or where two pedestrian signals are 10 feet or greater apart (PROWAG 308.3.1).</p> <p>In alterations, where the push buttons are less than 10ft apart, the audible walk indication shall be speech walk message (PROWAG R308.3.2).</p> <p>Shall be louder than ambient sound up to 5 dBA above ambient sound. Maximum volume above traffic sounds shall be 100 dBA (PROWAG R308.4).</p>		
Locator Tone	<p>Push buttons shall incorporate a locator tone. The locator tone shall be 0.15 seconds or less and repeat at 1 second intervals except when another audible indication from the same device is active. The locator tone shall be responsive to ambient sound and audible 6 to 12 feet from the push button to the building line, whichever is less. Shall be louder than ambient sound up to 5 dBA above ambient sound. Maximum volume above traffic sounds shall be 100 dBA (PROWAG R307.8).</p> <p>When a traffic signal is operating in flashing mode, the locator tone shall remain active, and the speech message should say the state of the signal (PROWAG R307.8.4).</p>	Refers to other standard publications for items not covered in the standards (KCRS Section 5.3).	N/A
Tactile Arrow	<p>Push buttons shall have a tactile arrow with high visual contrast that is parallel to the direction of travel (PROWAG R307.9).</p>	Refers to other standard publications for items not covered in the standards (KCRS Section 5.3).	N/A
Locator Tone and Audible Beacons	<p>When using audible beacons, the volume of the locator tone during ped change interval shall operate one of the following ways:</p> <ol style="list-style-type: none"> A. The louder audible walk indication and locator tone comes from the far end crosswalk. B. The louder locator tone comes from both ends of the crosswalk C. The louder locator tone comes from an additional speaker aimed at the center of the crosswalk and 	Refers to other standard publications for items not covered in the standards (KCRS Section 5.3).	N/A

Signals

Design Element	Requirement	Review	Recommendations
	<p>mounted on pedestrian signal head.</p> <p>(PROWAG 307.8.3)</p>		
Clear Space	<p>Clear spaces shall be 30 inches minimum by 48 inches minimum (PROWAG R404.3).</p> <p>Additional space is needed if it is confined on all or part of three sides (PROWAG 404.7).</p> <p>One full unobstructed side of a clear space shall adjoin a pedestrian access route or adjoin another clear space (PROWAG R404.6).</p>	Refers to other standard publications for items not covered in the standards (KCRS Section 5.3).	N/A
Reach Ranges	<p>For forward and parallel approaches, the high reach shall be 48 inches maximum and the low reach shall be 15 inches minimum above the ground surface (PROWAG R406.2).</p> <p>Forward reach over an obstruction is not permitted. Side reach from a parallel approach permits a 10-inch maximum obstruction depth and 34 inches maximum obstruction height (PROWAG R406.3).</p>	Refers to other standard publications for items not covered in the standards (KCRS Section 5.3).	N/A
Pedestrian Crossing Times	All pedestrian signal phase timing shall be based on a pedestrian clearance time that is calculated using a pedestrian walking speed of 3.5 feet/second or less from the location of the pedestrian push button to a pedestrian refuge island or the far side, minimum 7 seconds (PROWAG R306.2).	Refers to other standard publications for items not covered in the standards (KCRS Section 5.3).	N/A
At Roundabouts	<p>At each multi-lane segment of a roundabout containing a crosswalk, one or more of the following shall be provided: traffic control signal with pedestrian signal head, pedestrian hybrid beacon, pedestrian actuated RRFB, or a raised crossing (PROWAG R306.4.2).</p> <p>Edge detection shall be provided at roundabouts. A minimum of 24 inches of landscaping or nonprepared surface from crosswalk to crosswalk or a vertical edge treatment shall be applied with a bottom edge of 15 inches maximum above PCP (PROWAG 306.4)</p>	Refers to other standard publications for items not covered in the standards (KCRS Section 5.3).	N/A
At Multi-lane Channelized Turn Lanes	At signalized intersections and roundabouts with multi-lane channelized turn lane crossings, one or more of the following shall be provided: traffic control signal with pedestrian signal head, pedestrian hybrid beacon, pedestrian actuated	Refers to other standard publications for items not covered in the standards (KCRS Section 5.3).	N/A

Signals

Design Element	Requirement	Review	Recommendations
	RRFB, or a raised crossing (PROWAG R306.5).		

Other Pedestrian Areas

Other pedestrian areas include transit stops and work zones. Transit provides a critical lifeline of access and independence for those with limited mobility or vision. Transit stops have additional width requirements for boarding and alighting passengers, and work zones should provide the same level of accessibility as permanent pedestrian facilities.

Design Element	Requirement	Review	Recommendations
Transit Stops			
Boarding and Alighting Area Dimensions	Bus stop boarding and alighting areas shall provide a clear length of 96 inches minimum, measured perpendicular to the curb or vehicle street, and a clear width of 60 inches minimum, measured parallel to the vehicle street (PROWAG R309.1.1.1 & ADAS 810.2.2).	Refers to other standard publications for items not covered in the standards (KCRS Section 1.3).	N/A
Boarding and Alighting Area Slopes	Parallel to the street the grade of the bus stop boarding and alighting areas shall be the same as the street. Perpendicular to the street the slope of the bus stop boarding and alighting areas shall be 1:48 (2.1 percent) maximum (PROWAG R309.1.1.2 & ADAS 810.2.4).	Refers to other standard publications for items not covered in the standards (KCRS Section 1.3).	N/A
Transit Shelters	<p>Transit shelters shall be connected by PARs to boarding and alighting areas (PROWAG R309.2.1).</p> <p>Transit shelters shall provide a minimum clear space complying with R404 entirely within the shelter. Where seating is provided within transit shelters, the clear space shall be located either at one end of a seat or shall not overlap the area within 1.5 feet from the front edge of the seat (PROWAG R309.2.2).</p> <p>Bus shelters shall provide a minimum clear floor or ground space complying with 305 entirely within the shelter. Bus shelters shall be connected by an accessible route complying with 402 to a boarding and alighting area complying with 810.2 (ADAS 810.3).</p>	Refers to other standard publications for items not covered in the standards (KCRS Section 1.3).	N/A
Parking			
Parking Spaces	Where parking spaces are marked with lines, width measurements of parking spaces and access aisles shall be made from the centerline of the markings (ADAS 502.1).	Refers to other standard publications for items not covered in the standards (KCRS Section 1.3).	N/A

Other Pedestrian Areas

Design Element	Requirement	Review	Recommendations
Parking Identification	<p>Parking spaces shall be identified by signs displaying the international Symbol of Accessibility and be a minimum of 60 inches above the ground surface measured to the bottom of the sign (PROWAG R310.2.5)</p> <p>Parking space identification signs shall include the International Symbol of Accessibility complying with 703.7.2.1. Signs identifying van parking spaces shall contain the designation "van accessible." Signs shall be 60 inches minimum above the finish floor or ground surface measured to the bottom of the sign (ADAS 502.6).</p>	Refers to other standard publications for items not covered in the standards (KCRS Section 1.3).	N/A
Parallel Parking Spaces	<p>Parallel on-street parking shall be 24 feet long minches by 13 feet wide minches and not encroach on the traveled way. For alterations, if the adjacent PCP is not altered or would result in less than 9ft from the curb line to ROW line, the accessible parallel stalls can have the same dimension as the adjacent parallel parking stalls if placed at the end of a block or nearest to a midblock crossing and a curb ramp/blended transition is provided (PROWAG R310.2.1).</p> <p>The center 50 percent of the length of sidewalk or other surface, adjacent to the parallel parking space shall be free of obstructions (PROWAG R310.2.4).</p>	<p>"On-street parking shall be parallel parking with a minimum of 8 feet in width by 20 feet in length for end spaces, and 23 feet in length for intervening spaces" (KCRS Section 2.7).</p> <p>"Projects shall provide off street parking consistent with the requirements of Chapter 17.490" (KCC Section 17.420.037)</p> <p>"Off-street parking and access for physically disabled persons shall be provided in accordance with the regulations of the Americans with Disabilities Act (ADA) and Title 14." (KCC Section 17.490.060)</p>	N/A
Perpendicular Parking Spaces	<p>Car parking spaces shall be 96 inches wide minimum and van parking spaces shall be 132 inches wide minimum, shall be marked to define the width, and shall have an adjacent access aisle (ADAS 502.2).</p> <p>Van parking spaces shall be permitted to be 96 inches wide minimum where the access aisle is 96 inches wide minimum (ADAS 502.2 Exception).</p>	<p>Refers to other standard publications for items not covered in the standards (KCRS Section 1.3).</p> <p>"Off-street parking and access for physically disabled persons shall be provided in accordance with the regulations of the Americans with Disabilities Act (ADA) and Title 14." (KCC Section 17.490.060)</p>	N/A
Angled Parking Spaces	The width of angled parking space shall be 132 in (PROWAG R310.4.1).	<p>"Minimum parking dimensions for angled parking is 9 feet wide by 20 feet long" (KCRS Section 2.7).</p> <p>"Off-street parking and access for physically disabled persons shall be provided in accordance with the regulations of the Americans with Disabilities Act (ADA) and Title 14." (KCC Section 17.490.060)</p>	Add a provision to this section that the quantity and dimensions of ADA parking stalls shall meet ADA requirements.

Other Pedestrian Areas

Design Element	Requirement	Review	Recommendations
Parking Access Aisles	<p>Each angled on-street parking space shall have an adjacent access aisle 60 inches wide inches extending the full length of the parking space on the passenger side (PROWAG R310.4.2).</p> <p>Perpendicular on-street parking shall have an adjacent access aisle that is 96 inches wide inches for the full length of the parking space. One access aisle can serve two parking spaces if front and rear entry parking are both permitted. Where an access aisle serves one space and parking is restricted to either front or rear entry, the aisle shall be located on passenger side (PROWAG R310.3.1)</p> <p>Access aisles shall adjoin an accessible route. Two parking spaces shall be permitted to share a common access aisle (ADAS 502.3).</p> <p>Access aisles serving car and van parking spaces shall be 60 inches wide minimum (ADAS 502.3.1).</p> <p>Access aisles shall extend the full length of the parking spaces they serve (ADAS 502.3.2).</p> <p>Access aisles shall be marked so as to discourage parking in them (PROWAG R310.5.1 and ADAS 502.3.3).</p> <p>Access aisles shall not overlap the vehicular way. Access aisles shall be permitted to be placed on either side of the parking space except for angled van parking spaces which shall have access aisles located on the passenger side of the parking spaces (ADAS 502.3.4).</p>	<p>Refers to other standard publications for items not covered in the standards (KCRS Section 1.3).</p> <p>"Off-street parking and access for physically disabled persons shall be provided in accordance with the regulations of the Americans with Disabilities Act (ADA) and Title 14." (KCC Section 17.490.060)</p>	N/A
Alternative Pedestrian Access Routes			
Alternate Pedestrian Access Route	<p>When a pedestrian circulation path is temporarily not accessible due to construction, maintenance operations, closure, or other similar conditions, an alternate pedestrian access route must be provided (PROWAG R204.1).</p>	<p>"Traffic controls, including detours for all utility work, shall conform to Chapter 8 of these Standards and the current MUTCD. A traffic control plan shall be required for Right of way Construction Permits that affect</p>	N/A

Other Pedestrian Areas

Design Element	Requirement	Review	Recommendations
		vehicle and/or pedestrian traffic” (KCRS Section 7.8.2).	
Driveways			
Driveways	<p>The cross slope shall be 1:48 (2.1 percent) maximum (PROWAG R302.5.1).</p> <p>Cross slope of ramp runs shall not be steeper than 1:48. (ADAS 405.3)</p> <p>The running slope shall be 1:12 (8.3 percent) maximum but shall not require the ramp length to exceed 15.0 feet (PROWAG R304.3.1).</p> <p>For driveways that are yield or stop controlled, or at traffic signals, detectable warning surface shall be provided where the PCP meets the driveway (PROWAG R305.2.8).</p>	<p>A running slope 12:1 slope is shown (KCRS Figure 4-3).</p> <p>A cross slope 1.5 % maximum and 2% slope is shown (KCRS Figure 4-3).</p> <p>The following note is included “When sidewalk is adjacent to a roadway, the slope is allowed to match the profile of the road” (KCRS Figure 4-3).</p> <p>A cross slope of 2% slope is shown (KCRS Figures 4-4 and 4-5).</p>	<p>Recommend including a desired cross slope of 1.5% or flatter to allow for construction tolerances with 2% as the maximum cross slope on all driveway standard details.</p> <p>At minimum, resolve the discrepancy of the cross slope labels on KCRS Figure 4-3.</p> <p>Recommend including a desired running slope for driveway slopes within the pedestrian access route of 7.5 percent or flatter to allow for construction tolerances with 8.3 percent as the maximum running slope.</p>
Ramps			
Ramp Width	The clear width of a ramp run shall be 48 inches minimum and, where handrails are provided, the clear width between handrails shall be 48 inches minimum (PROWAG R407.4 & ADAS 405.5).	Refers to other standard publications for items not covered in the standards (KCRS Section 1.3).	N/A
Running Slope	<p>Ramp runs shall have a running slope of 1:12 (8.3 percent) maximum (PROWAG R407.2)</p> <p>Ramp runs shall have a running slope not steeper than 1:12. In existing sites, buildings, and facilities, ramps shall be permitted to have running slopes steeper than 1:12, complying with Table 405.2 where such slopes are necessary due to space limitations (ADAS 405.2).</p>	Refers to other standard publications for items not covered in the standards (KCRS Section 1.3).	N/A
Cross Slope	<p>The cross slope of ramp runs shall be 1:48 (2.1 percent) maximum (PROWAG R407.3).</p> <p>Cross slope of ramp runs shall not be steeper than 1:48. (ADAS 405.3)</p>	Refers to other standard publications for items not covered in the standards (KCRS Section 1.3).	N/A
Rise	The rise for any ramp run shall be 30 inches maximum (PROWAG R407.5 & ADAS 405.6).	Refers to other standard publications for items not covered in the standards (KCRS Section 1.3).	N/A
Landing Size	<p>Ramps shall have landings at the top and the bottom of each ramp run (PROWAG R407.6 & ADAS 405.7).</p> <p>The landing clear width shall be at least as wide as the widest ramp run leading to the landing (PROAG R407.6.2 & ADAS 405.7.2)</p>	Refers to other standard publications for items not covered in the standards (KCRS Section 1.3).	N/A

Other Pedestrian Areas

Design Element	Requirement	Review	Recommendations
	<p>The landing clear length shall be 60 inches long minimum (PROWAG R407.6.3 & ADAS 405.7.3)</p> <p>Ramps that change direction between runs at landings shall have a clear landing 60 inches by 60 inches minimum (PROWAG R407.6.4 & ADAS 405.7.4).</p>		
Landing Slope	<p>Landing slopes shall be 1:48 (2.1 percent) maximum parallel and perpendicular to the ramp running slope (PROWAG R407.6.1 & ADAS 405.7.1).</p>	<p>Refers to other standard publications for items not covered in the standards (KCRS Section 1.3).</p>	N/A
Edge Protection	<p>Except for those adjoining ramp run, stairway, or other PCP, edge protection, complying with the following, shall be provided on each side of ramp runs and landings:</p> <ul style="list-style-type: none"> • The surface of the ramp run or landing extend 12 inches inches beyond the inside face of the handrail • A curb that is 4 inches high minim or barrier that prevents passage of a 4 inches diameter sphere. <p>(PROWAG R407.9 & ADAS 405.9)</p>	<p>Refers to other standard publications for items not covered in the standards (KCRS Section 1.3).</p>	N/A
Stairways			
Stairway Treads and Risers	<p>All steps on a flight of stairs shall have uniform riser heights and uniform tread depths. Risers shall be 4 inches high minimum and 7 inches high maximum. Treads shall be 11 inches deep minimum (PROWAG R408.2 & ADAS 504.2).</p> <p>Open risers are not permitted (PROWAG R408.3 & ADAS 504.3).</p> <p>The radius of curvature at the leading edge of the tread shall be 0.5 inches maximum. Nosings that project beyond risers shall have the underside of the leading edge curved or beveled. Risers shall be permitted to slope under the tread at an angle of 30 degrees maximum from vertical. The permitted projection of the nosing shall extend 1.5 inches maximum over the tread below (PROWAG R408.5 & ADAS 504.5).</p> <p>The leading edge of the step tread and top landing shall be marked by a 1 inches wide minches stripe that</p>	<p>Refers to other standard publications for items not covered in the standards (KCRS Section 1.3).</p>	N/A

Other Pedestrian Areas

Design Element	Requirement	Review	Recommendations
	visually contrasts with the rest of the step tread or circulation path (PROWAG R408.6).		
Handrails			
Handrails	<p>Stairways shall have handrails (PROWAG R409.2).</p> <p>Handrails are required on ramp runs with a rise greater than 6 inches and on certain stairways (PROWAG R407.8 & ADAS 405.8).</p> <p>Where required, handrails shall be provided on both sides of ramps and stairways (PRWOAG R409.2 & ADAS 505.2).</p> <p>Top of gripping surfaces of handrails shall be 34 inches minimum and 38 inches maximum vertically above walking surfaces, ramp surfaces, and stair nosings. Handrails shall be at a consistent height above walking surfaces, ramp surfaces, and stair nosings (PROWAG R409.4 & ADAS 505.4).</p> <p>Clearance between handrail gripping surfaces and adjacent surfaces shall be 1.5 inches minimum (PROWAG R409.5 & ADAS 505.5).</p> <p>Handrail gripping surfaces shall be continuous along their length and shall not be obstructed along their tops or sides. The bottoms of handrail gripping surfaces shall not be obstructed for more than 20 percent of their length. Where provided, horizontal projections shall occur 1.5 inches minimum below the bottom of the handrail gripping surface (PROWAG R409.6 & ADAS 505.6).</p>	Refers to other standard publications for items not covered in the standards (KCRS Section 1.3).	N/A
Handrail Extension on Ramps	Ramp handrails shall extend horizontally above the landing for 12 inches minimum beyond the top and bottom of ramp runs. Extensions shall return to a wall, guard, or the landing surface, or shall be continuous to the handrail of an adjacent ramp run. (PROWAG R409.10.1 & ADAS 505.10.1).	Refers to other standard publications for items not covered in the standards (KCRS Section 1.3).	N/A
Handrail Extension on Stairways	At the top of a stair flight, handrails shall extend horizontally above the landing for 12 inches minimum beginning directly above the first riser nosing. Extensions shall return to a wall, guard, or the landing surface, or shall be continuous to the handrail of an adjacent stair flight (PROWAG R409.10.2 & ADAS 505.10.2).	Refers to other standard publications for items not covered in the standards (KCRS Section 1.3).	N/A

Other Pedestrian Areas

Design Element	Requirement	Review	Recommendations
	At the bottom of a stair flight, handrails shall extend at the slope of the stair flight for a horizontal distance at least equal to one tread depth beyond the last riser nosing. Extensions shall return to a wall, guard, or the landing surface, or shall be continuous to the handrail of an adjacent stair flight. (PROWAG R409.10.3 & ADAS 505.10.3).		
Handrail Cross Section	<p>Handrail gripping surfaces with a circular cross section shall have an outside diameter of 1.25 inches minimum and 2 inches maximum (PROWAG R409.7.1 & ADAS 505.7).</p> <p>Handrail gripping surfaces with a non-circular cross section shall have a perimeter dimension of 4 inches minimum and 6.25 inches maximum, and a cross-section dimension of 2.25 inches maximum (PROWAG R409.7.2 & ADAS 505.7).</p>	Refers to other standard publications for items not covered in the standards (KCRS Section 1.3).	N/A

Railways

Railroad Flangeway Gaps	<p>Flangeway gaps at pedestrian at-grade rail crossings shall be 2.5 inches maximum for tracks not subject to 49 CFR part 213 and shall be 3 inches maximum for tracks subject to 49 CFR part 213. (PROWAG R302.7.4).</p> <p>Where a PAR crosses the rail, the PAR surface shall be level and flush with the top of the rail at the outer edge of the rail and the surface between the rails shall be aligned with the top of the rail (PROWAG R302.6.4.1).</p> <p>Where a circulation path serving boarding platforms crosses tracks, it shall comply with 402. Openings for wheel flanges shall be permitted to be 0.5 inches maximum (ADAS 810.10).</p>	Refers to other standard publications for items not covered in the standards (KCRS Section 1.3).	N/A
Detectable Warning Surfaces at Rail Crossings	<p>At pedestrian at-grade rail crossings not located within a street, detectable warning surfaces shall extend the full width of the PCP (PROWAG R304.1.4)</p> <p>At pedestrian at-grade rail crossings not located within a street, detectable warning surface shall be located on each side of the rail crossing. The edge of the detectable warning surface nearest the rail crossing shall be 6.0 feet minimum and 15.0 feet maximum from the centerline of the nearest rail. Where</p>	Refers to other standard publications for items not covered in the standards (KCRS Section 1.3).	N/A

Other Pedestrian Areas

Design Element	Requirement	Review	Recommendations
	pedestrian gates are provided, detectable warning surfaces shall be placed on the side of the gates opposite the rail. (PROWAG R305.2.5).		
Detectable Warning Surfaces at Rail Boarding Areas	At boarding platforms for rail vehicles, detectable warning surfaces shall be placed at the boarding edge of the platform (PROWAG R305.2.6). At boarding and alighting areas at sidewalk or street level transit stops for rail vehicles, detectable warning surfaces shall be placed at the side of the boarding and alighting area facing the rail vehicles (PROWAG R305.2.7).	Refers to other standard publications for items not covered in the standards (KCRS Section 1.3).	N/A

Appendix B: Existing Data Inventory

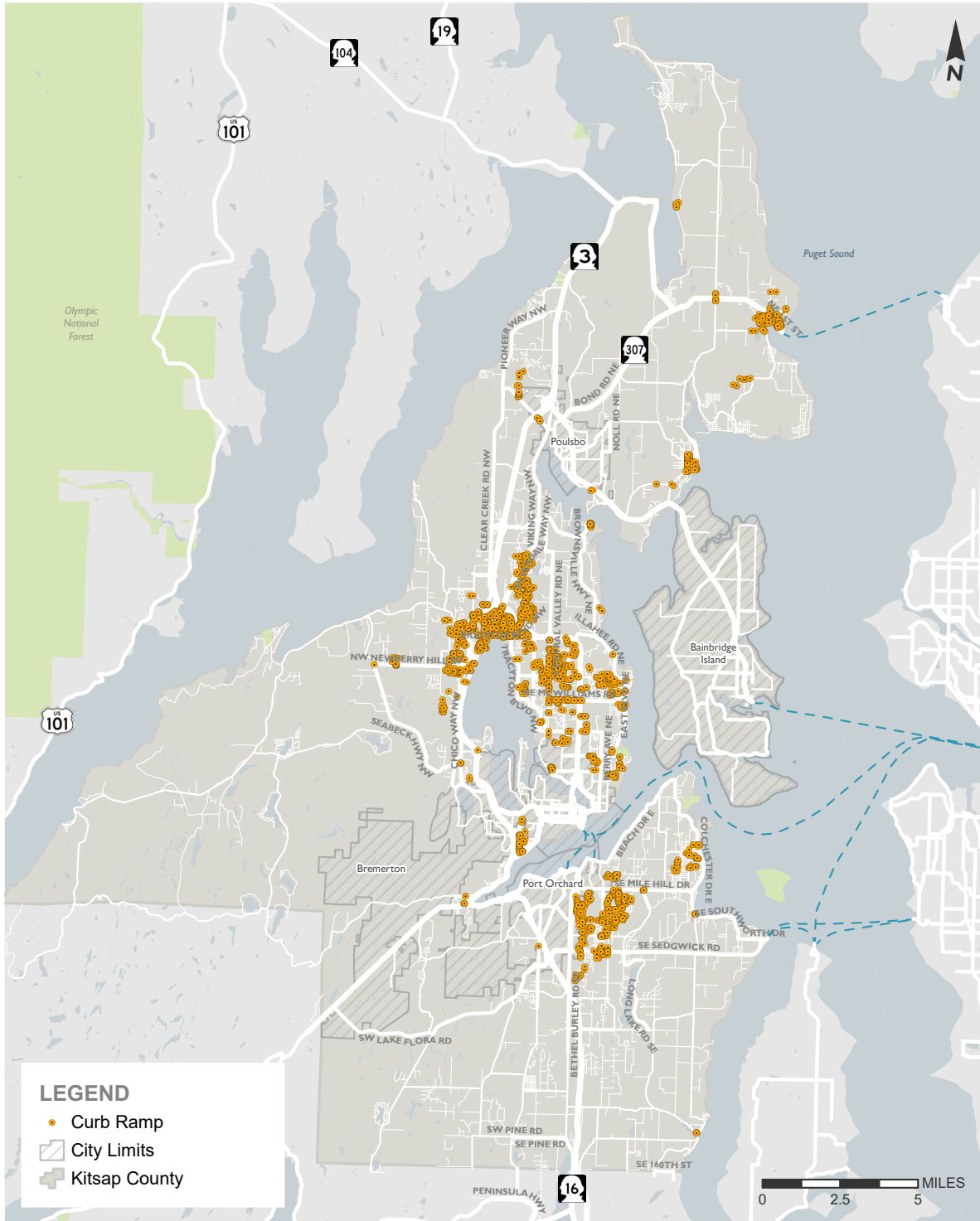

Curb Ramp Inventory
Kitsap County ADA Transition Plan

FIGURE
I-1

DRAFT



M:\22\1.22438.00 - Kitsap County ADA Transition Plan\GIS\ArcGISPro\KitsapCountyADA\KitsapCountyADA_FigureExport.aprx

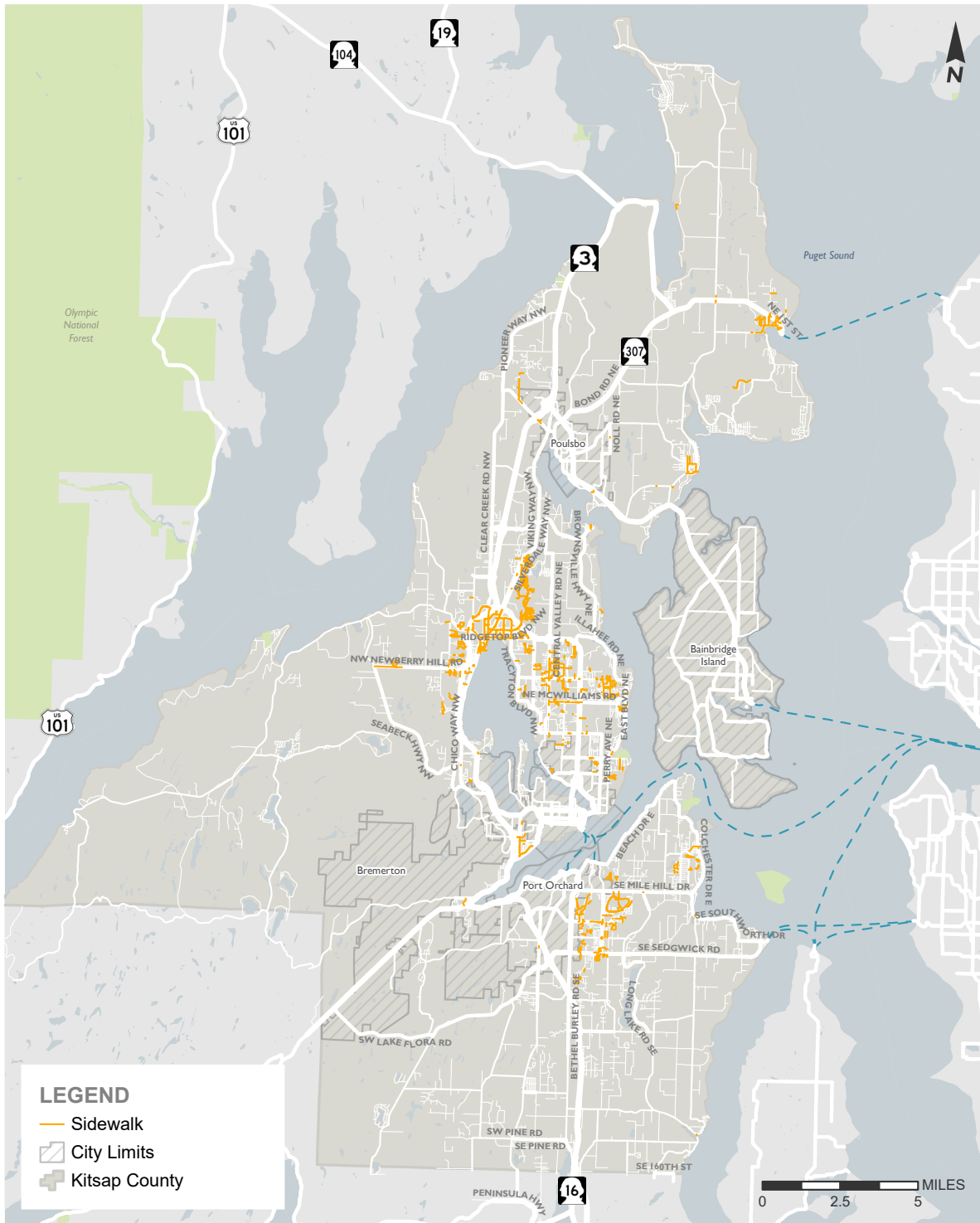

Sidewalk/Pathway Inventory

Kitsap County ADA Transition Plan

DRAFT



FIGURE

I-2

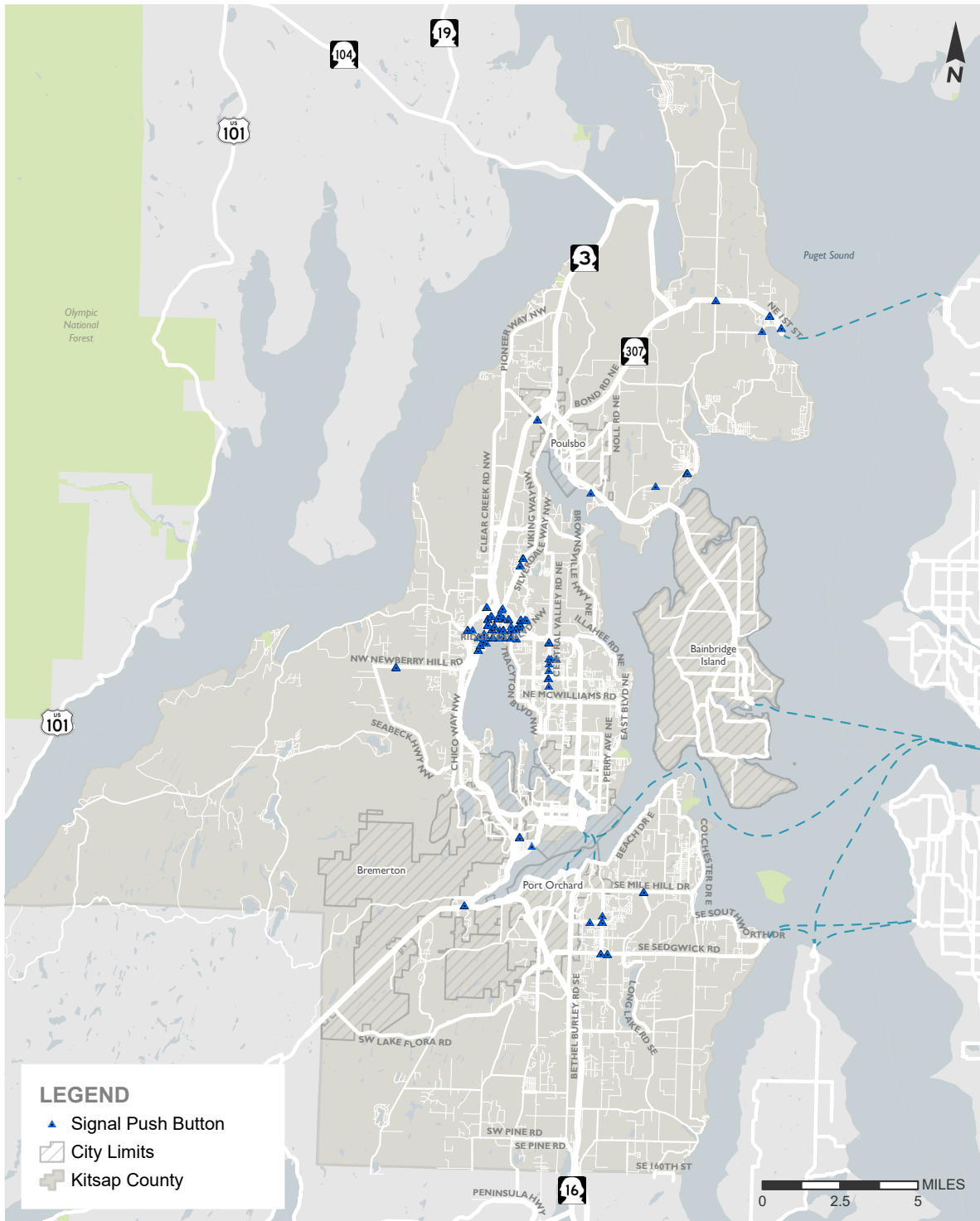

Signal Push Button Inventory

Kitsap County ADA Transition Plan

DRAFT



FIGURE

I-3

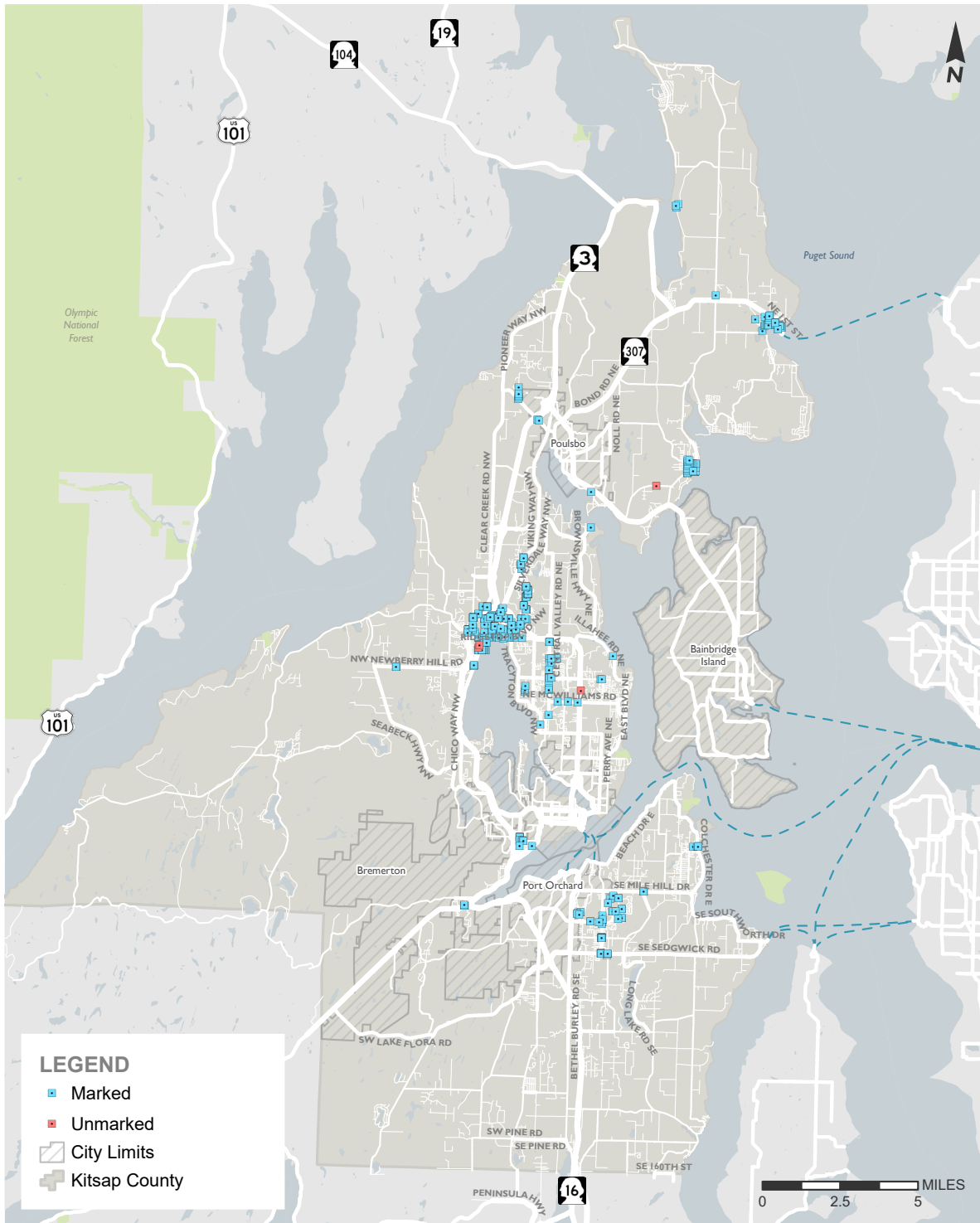

Crosswalk Inventory
Kitsap County ADA Transition Plan

FIGURE

I-4

DRAFT



M:\21\1.22438.00 - Kitsap County ADA Transition Plan\GIS\ArcGISPro\KitsapCountyADA\KitsapCountyADA_FigureExport.aprx

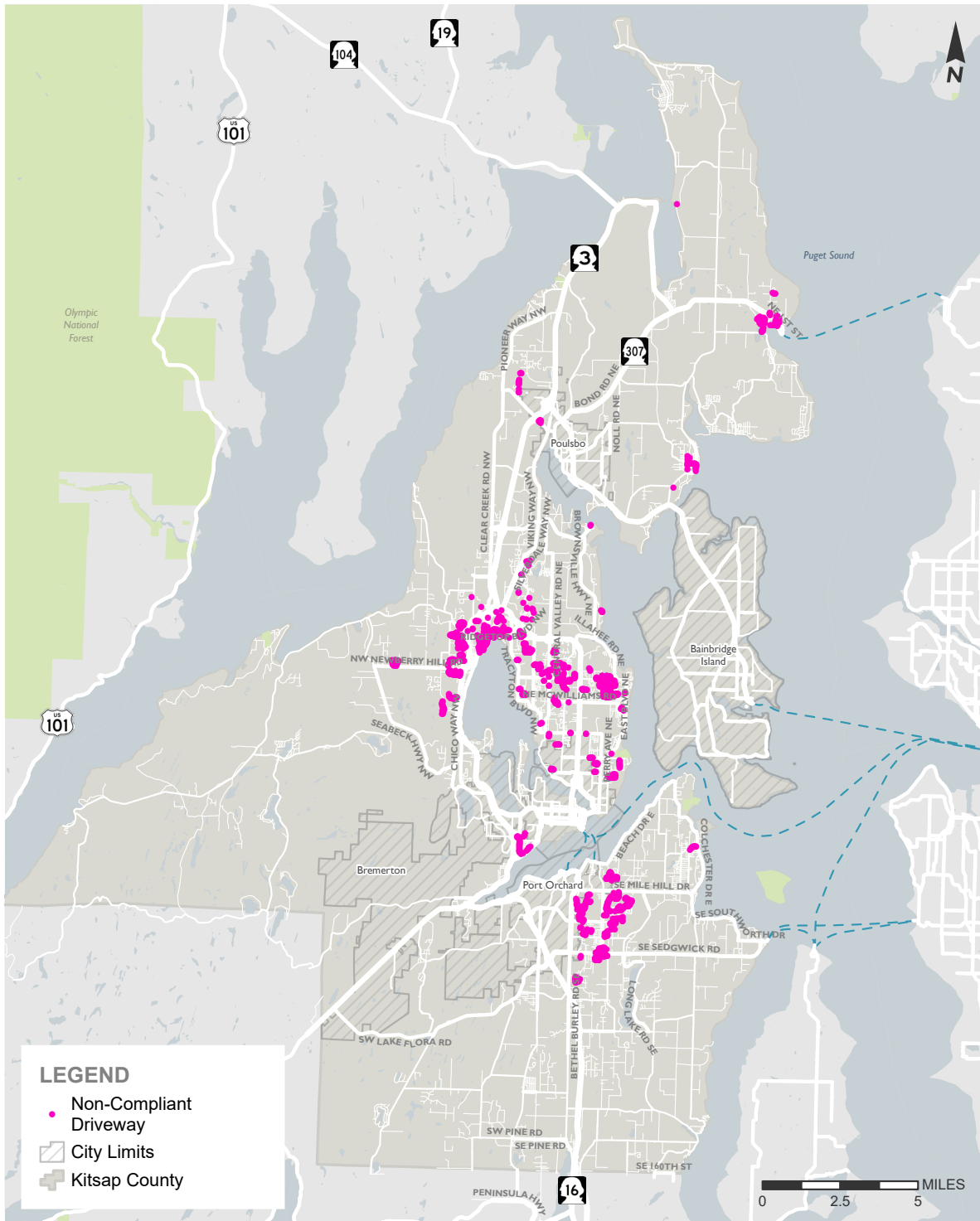

Non-Compliant Driveway Inventory

Kitsap County ADA Transition Plan

DRAFT



FIGURE

I-5

Appendix C: Prioritization Criteria

ADA Transition Plan Prioritization Process

Public Right-of-Way

To focus efforts toward facilities that pose the largest barrier within the public right-of-way, an analysis of the accessibility of each pedestrian facility and its proximity to public destinations such as schools, libraries, parks, transit, and County buildings was completed. The result of this analysis was a prioritized list of projects, with the highest benefit projects identified for barrier removal first.

To complete this assessment, a multi-criteria analysis was conducted to determine which facilities did not meet existing sidewalks and curb ramp standards. Each attribute collected in the field was compared against PROWAG requirements.

If the facility did not meet PROWAG criteria or was located near public destinations, points were assigned, with the number of points dependent on the relative importance or proximity. Sidewalks or curb ramps with poor PROWAG compliance and a number of proximate destinations received a high score and were prioritized for removal while PROWAG compliant ramps far from public destinations received a score of zero. Missing curb ramps were assigned the greatest number of points.

Accessibility Prioritization (aka Accessibility Index Score)

A number of criteria were used to establish the extent to which each pedestrian facility did or did not present a barrier to accessible mobility. The table below shows these criteria, the threshold used to identify them as a barrier, and the score used to indicate the severity of each barrier relative to each other. Pedestrian facilities with a higher Accessibility Index Score (AIS) presented a large accessibility barrier and received a higher score. Facilities with fewer or no barriers received lower scores.

Below is an example of typical weighted values to equal a total possible score of 30.

ACCESSIBILITY INDEX SCORE	CRITERIA	THRESHOLD	SCORE	MAX. POSSIBLE SCORE
Sidewalks	Width	In ROW, < 48 inches or >= 48 - < 60 inches w/ out Pullouts. On-Site, < 36 inches	4	4
	Run Slope	> 5% (and Not Similar to Roadway Grade if in ROW)	3	3
	Cross Slope	> 2%	1	3
	Cross Slope	> 2.4%	1	
	Cross Slope	> 3%	1	
	Surface Condition	< Average	2	2
	Vertical Discontinuity	Barriers Present >= 1	1	3

ACCESSIBILITY INDEX SCORE	CRITERIA	THRESHOLD	SCORE	MAX. POSSIBLE SCORE
	> ¼ inch and <= ½ inch Without Bevel or >½ inch			30
	Vertical Discontinuity	Barriers Present >= 5	1	
	Vertical Discontinuity	Barriers Present >= 10	1	
	Horizontal Discontinuity > ½ inch	Barriers Present >= 1	1	
	Horizontal Discontinuity	Barriers Present >= 5	1	
	Horizontal Discontinuity	Barriers Present >= 10	1	
	Fixed Obstacles	Barriers Present >= 1	1	
	Fixed Obstacles	Barriers Present >= 2	1	
	Fixed Obstacles	Barriers Present >= 3	1	
	Moveable Object	Barriers Present >= 1	1	
	Moveable Object	Barriers Present >= 2	1	
	Moveable Object	Barriers Present >= 3	1	
	Protruding Object	Barriers Present >= 1	1	
	Protruding Object	Barriers Present >= 2	1	
	Protruding Object	Barriers Present >= 3	1	
	Non-Compliant Driveway Non-Compliant >2% Cross-Slope, and/or Non-Concurrent Grade Break and/or >8.3% Running Slope	Barriers Present >= 1	1	
	Non-Compliant Driveway	Barriers Present >= 2	1	
	Non-Compliant Driveway	Barriers Present >= 3	1	
Maximum Sidewalk (AIS) Score				30
Curb Ramps (Max. Score)	Ramp Width	< 48 inches	30	30
	Run Slope	> 8.3% (Less Than 15 feet) or > 5% (Blended)	30	30
	Cross Slope	> 2% - <= 3%	20	30
	Cross Slope	> 3%	10	
	Curb Ramp Type	Non-Compliant Type	30	30
Curb Ramps	Accessible Path	No	2	2
	Turning Space	None or Width < full Width of Ramp or Length < 48 inches	5	5
	Turning Space Cross Slope	> 2%	3	3
	Truncated Domes (DWS)	No	3	3
	Truncated Domes (DWS) Placement	Other than Back of Curb	1	3
	Truncated Domes (DWS) Depth	< 2 feet	1	
	Truncated Domes (DWS) Width	Less than Full Width	1	
	Flare Slope	> 10%	2	2
	Grade Break	Not Concurrent	2	2

ACCESSIBILITY INDEX SCORE	CRITERIA	THRESHOLD	SCORE	MAX. POSSIBLE SCORE
	Counter Slope	> 5%	2	2
	Lip	> ¼ inch	2	2
	Roadway Clear Space	< 4ft x 4ft	2	2
	Receiving Ramp	No	2	2
	End Inside of Marked Crosswalk if Present	No	2	2
	Maximum Curb Ramp (AIS) Score			
Signal Push Buttons	Push Button is <= 10 feet from Curb in Direction of Travel	No	2	2
	Push Button is <= 5 feet from Extension of Crosswalk Width Edge	No	2	2
	Force to Activate Push Button is <= 5 lbs.	No	2	2
	Push Button Includes Vibe Feedback During "Walk" Phase	No	2	2
	Push Button is >= 2 inches in Diameter and Includes Visual Contrast from Housing	No	2	2
	Tactile Arrow Present on Push Button	No	2	2
	Nearest Push Button > 10 feet Away or Push Button Includes Audible Speech Indicating "Walk" Phase	No	2	2
	Level Clear Space at Push Button that Includes Minimum 30-inch x 48 inch Landing Area and < 2% Slope in Any Direction	No	3	3
	Reach Depth from Landing to Push Button is <= 10 inches	No	2	2
	Mounting Height of Push Button	Mounting Height of Push Button from Landing Area is < 42 inches or > 48 inches	2	2
	Directional Arrow Exists on Push Button Face, Housing, or Mounting and is Parallel to Crossing	No	2	2
	Audible Tone indicating "Walk" Phase or Audible Speech indicating "Walk" Phase Present	No	3	3
	Locator Tone during "Don't Walk" Phases Present	No	2	2
	APS-Style Push Button Housing	No	2	2
	Maximum Signal Push button (AIS) Score			

ACCESSIBILITY INDEX SCORE	CRITERIA	THRESHOLD	SCORE	MAX. POSSIBLE SCORE
Crosswalks	Width	< 6 feet	6	6
	Run Slope	> 5%	12	12
	Cross Slope	> 5% at Non-Stop/Yield Controlled Intersections or > 2% at Any Other Type Except for Mid-Block Crossings	12	12
	Maximum Crosswalk (AIS) Score			30

Location Prioritization (aka Location Index Score)

A number of destinations were used to identify high priority pedestrian facilities within the County. This was done by identifying public destinations such as public buildings, transit and parks and identifying pedestrian facilities within close proximity of one or more of these destinations.

Pedestrian facilities within the identified proximity were assigned points based on each destination they were close to, as shown in the table below. This measure is called the Location Index Score (LIS), which identified high pedestrian generating overlapping areas. Ultimately the more pedestrian generating areas an asset was within, the higher the number. Community Defined Destinations criteria was added to the Location Index Score (LIS) following comments and results received from open house attendees, County staff, other stakeholders during engagement and public outreach. This assisted in factoring in what’s important to the citizens and community to help with the overall prioritization.

Below is an example of typical weighted values to equal a total possible score of 45.

LOCATION CRITERIA	RATING CRITERIA	POSSIBLE SCORE
Schools		
Proximity to Schools	Within 1/8-mile radius of school	5
Walk-To-School Route Proximity	Within 1/2-mile radius of school	5
Parks	Within 1/8-mile radius of park	5
Transit		

High-Capacity Transit	Within 1/8-mile of high-capacity transit	5
Transit Stops	Within 1/8-mile of transit stop	5
Traffic Signal/Roundabout	Within 1/8-mile of signal or roundabout	5
Public Buildings	Within 1/8-mile of location	5
Downtown / Urban / Commercial Business Centers	Within 1/4-mile radius of Downtown, Urban and Commercial Business Center Zoning	5
Community Defined Destinations (defined by Stakeholder/Public Engagement*)	Within 1/8-mile of location	5
TOTAL LOCATION INDEX SCORE (LIS)		45

* Note: Community Defined Destinations to be identified based on public outreach, ADA surveys, etc. on what locations are more important, thus giving extra weight to those community defined destinations.

Barrier Removal Priorities (Combined Composite Index Score)

By combining the Accessibility Index Score and Location Index Score, a Combined Composite Index Score was developed. Together, these measures prioritize barrier removal at locations where pedestrian facilities present a barrier and where pedestrians would be expected.

Facilities with the highest score should be addressed first (46+ points) represent facilities that present a clear physical barrier and are in high-demand areas. These should be addressed first. Facilities with lower scores (0-15 points) have minor barriers, and are in locations where pedestrian demand would be expected to be lower, and should be address last. These scores are relative, comparing one facility to the other. The ranges for medium and high priority were defined based on review of the identified barriers and assessment of the relative barrier they present. It should be noted that while some barriers have a lower priority, they still should be removed.

Appendix D: Stakeholder Outreach

MEMORANDUM

Date:	May 7, 2024	TG:	1.22438
To:	Kitsap County		
From:	Patrick Lynch, AICP– Transpo Group Jewell Hamilton, STP – Transpo Group		
Subject:	Kitsap ADA Transition Plan Stakeholder Engagement		

The following document summarizes the Kitsap County ADA Transition Plan stakeholder engagement process and identifies trends and priorities based on the community’s responses.

Public and stakeholder input is an essential element in the Transition Plan development and Self-Evaluation processes. ADA implementation regulations require public entities to provide an opportunity to interested persons, including individuals with disabilities or organizations representing individuals with disabilities, to participate in the Self-Evaluation process and development of the Transition Plan by submitting comments (28 CFR 35.105(b) and 28 CFR 35.150(d)(1)). The County’s three primary goals for conducting public outreach activities prior to adopting the plan include the following:

- Inform the public about the County’s plan and processes regarding removal of barriers to accessibility within the rights-of-way. Provide information to assist interested parties to understand the issues faced by the County, the alternatives considered, and planned actions.
- Obtain public comment to identify any errors or gaps in the proposed accessibility transition plan for the public rights-of-way, specifically on prioritization and grievance processes.
- Meet Title II requirements for public comment opportunity.

Engagement Survey

The engagement survey was promoted by Kitsap County between late October 2023 through March 2024 to request responses via the County’s virtual open house website.

An online survey was made available to residents through Kitsap County’s ADA Transition Plan website, www.kitsapada.com. The online open house provided context on the County’s ADA Transition Plan process and allowed viewers to respond to the feedback survey while it was open. The feedback survey asked respondents to provide input on their disability status, travel modes, barriers to travel that they experience, and priorities for improving ADA facilities. The survey contained several sections that asked the respondent to comment on the following subtexts:

1. Whether they have a disability, or if they support someone with one,
2. Which type of accessibility barriers they currently experience,
3. How they rate the accessibility conditions of existing right-of-way facilities; and,
4. What facility types they believe should be prioritized when removing accessibility barriers.

A full account of the survey findings can be found in Attachment A. In addition to the online survey, an interactive map was available for respondents to pinpoint areas of concern.

The online survey received 198 unique responses. Out of the 198 responses, 100% were residents of Kitsap County. Respondents did not indicate whether they resided in an incorporated or unincorporated area of the county. The survey respondents traveled in Kitsap County for work, recreation, medical appointments, social or community services, volunteer and social activities, church, and shopping. Of all responses, 36% (71 respondents) indicated they have a disability that impacts the way they travel and 29% (58 respondents) reported supporting someone with a disability. Ten of these respondents reported that they both have a disability and support someone with a disability. A summary of respondents’ disability status is shown in Figure 1.

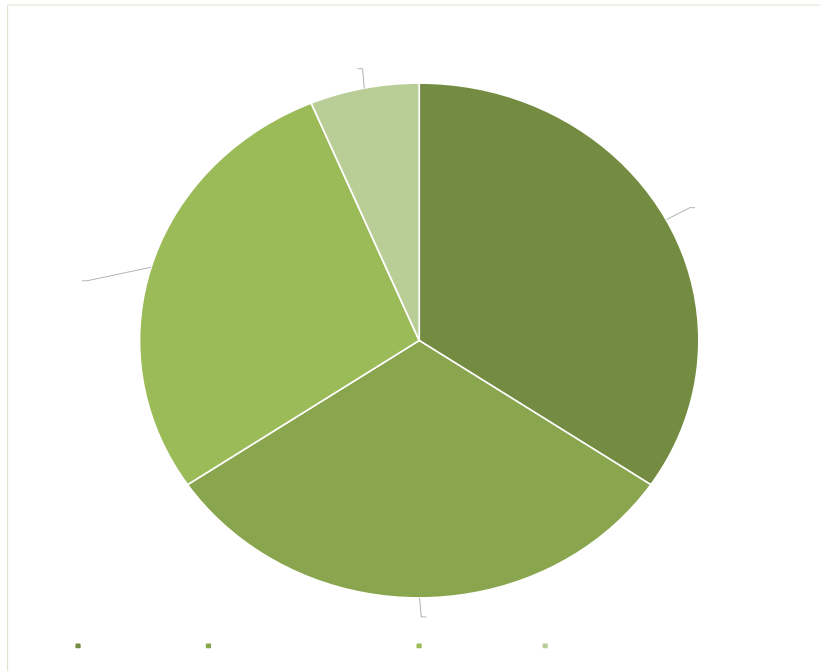

Figure 1 Disability Status

The survey asked respondents to evaluate their use of frequent travel modes through the county, including driving, transit or paratransit shuttle, wheelchair, bike, or walking with or without assistance. Respondents were able to indicate if they use multiple travel modes.

As shown in Figure 2, the survey respondents predominantly drive and walk, with 162 of the 198 total respondents (82%) indicating that they drive. A total of 92 respondents (46%) indicated that they walk without assistance. Another 55 respondents, (28%) indicated that they walk with assistive persons or devices including canes and walkers, and 5 respondents (3%) walk with a service animal. Other respondents indicated prevalent use of alternative modes, with 42 respondents (21%) taking transit or paratransit, 25 respondents (13%) using a wheelchair, and 28 respondents (14%) using a bike/scooter. Survey respondents were asked to identify barriers in the public right-of-way that limit participation and access to services in Kitsap County.



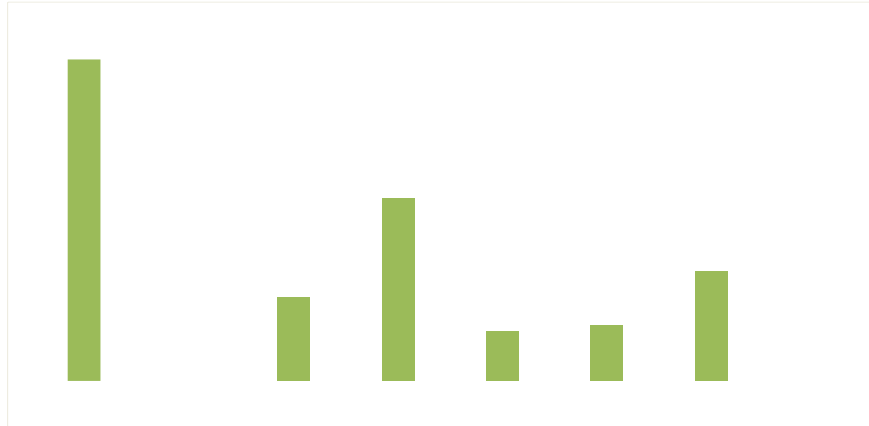

Figure 2 Travel Mode

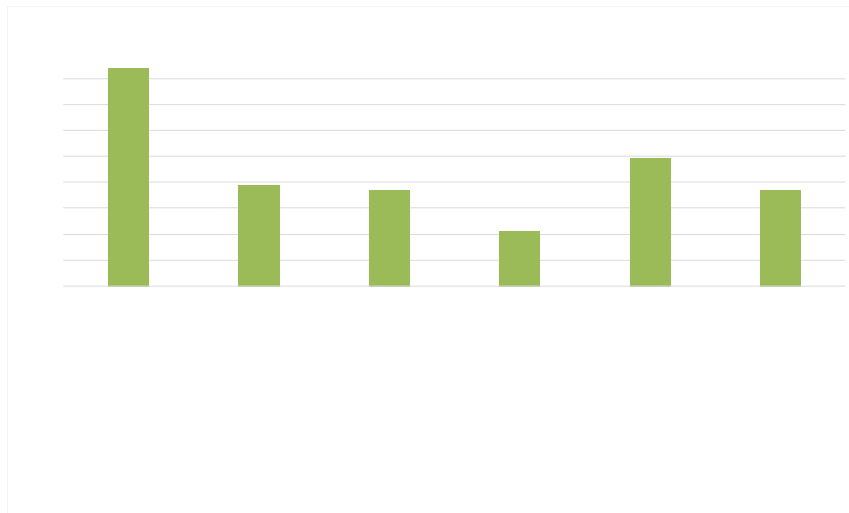

Figure 3 Observed Barriers in Public Right-of-Way

As shown on Figure 3, several barriers received significant response from the survey, with lack of sidewalk and unavailability of ADA designated parking stalls selected most frequently. In addition, curb ramp barriers and crosswalk barriers were identified as challenges. Survey respondents selecting the “Other” category identified barriers including challenging building entrances and other structural barriers, lack of various kinds of support services, and lack of ADA compliant ferry access.

Improvement Priorities

The survey respondents ranked their accessibility priorities within the County’s public right-of-way as first and second priority.



Ranking an item as a first priority improvement was given a greater weight than second priority to emphasize the improvement's importance. A first priority ranking scored 3 points in the weighted scoring system, while a second priority ranking scored one point.

When considering weighted scores, the top three priorities among survey respondents were government buildings, hospitals and other medical facilities, and retail services. A summary of the weighted ranked priority locations is included in Figure 4. These weighted ranked priorities were utilized in the prioritization of barrier removal in the County's transition plan. The unweighted first and second priority survey responses are shown in Figure 5.

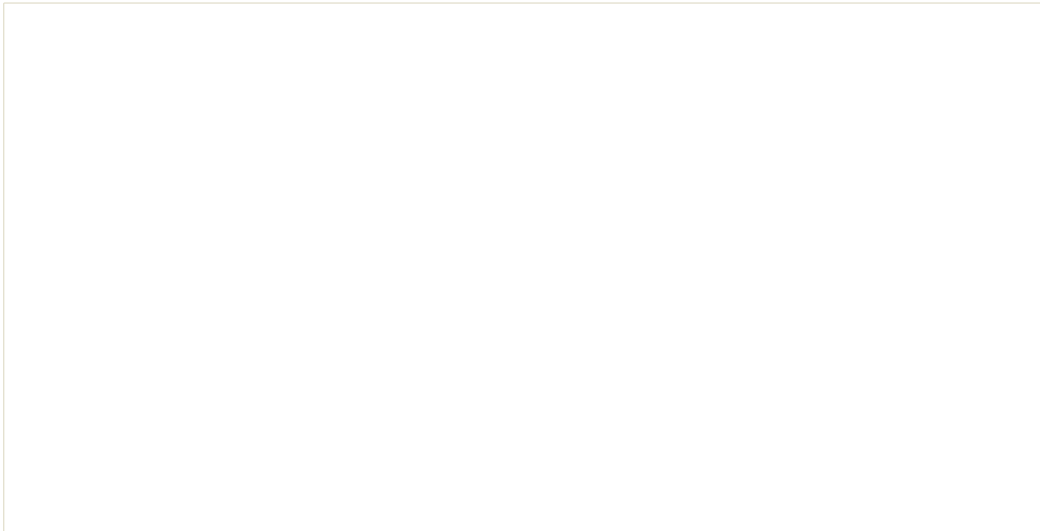

Figure 4 Weighted Improvement Priority Ranking



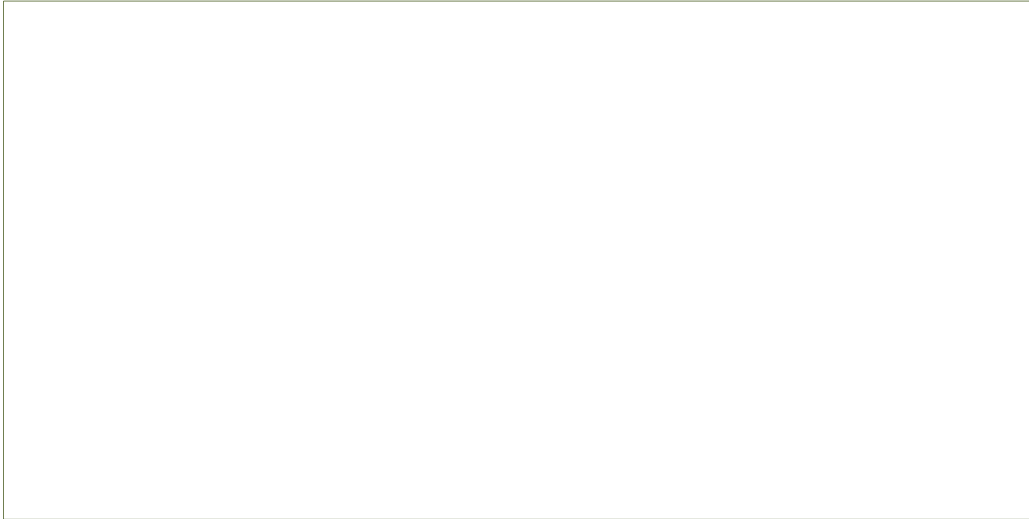

Figure 5 Unweighted First and Second Improvement Priority Ranking

Respondents were also given the opportunity to identify locations where they have experienced mobility or accessibility challenges in Kitsap County. Locations were able to be identified via written survey responses and through an online mapping tool provided on the public engagement website. Key locations identified via written survey results and the online mapping tool are summarized in Table 1. Lack of sidewalk or limited access to sidewalks were identified as the most common barriers among the locations identified in Table 1. Many acknowledgements were given to the lack of sidewalk or safe crossings in downtown areas, on the County’s highways, and around the County’s parks. It should be noted that several of the facilities or features identified via the write-in responses are not covered under the ADA, or within the scope of this plan. A complete listing of identified locations is given in Attachment A.

Table 1. Identified Accessibility Barriers

County Locations and/or Landmarks	County Roadways or Roadway Segments
Port Orchard Strip Mall	Bethel Road SE
Grocery Outlet in Kingston	SR 104
The Trails Silverdale	Clear Creek and Greaves
Saltwater Park in Keyport	SR 308
Point No Point Lighthouse	Point No Point Road

Meeting ADA Standards

Per 28 CFR 35.150(d)(1), public involvement is required as follows: A public entity shall provide an opportunity to interested persons, including individuals with disabilities or organizations representing individuals with disabilities, to participate in the development of the transition plan by submitting comments. A copy of the transition plan shall be made available for public inspection.

The County has engaged with the public for feedback on developing the ADA transition plan in a manner that meets Title VI of the Civil Rights act. Title VI of the Civil Rights Act of 1964 is a federal statute and provides that no person shall, on the grounds of race, color, or national origin, be excluded from



participation in, be denied the benefits of, or be subjected to discrimination under any program or activity receiving federal financial assistance. This includes matters related to language access or limited English proficient (LEP) persons.

Additional Outreach

A draft version of the ADA transition plan will be made available for public comment. Notice will be sent out via a mailer to all addresses in the county, County e-news, and the County newsletter that will inform people how to view the plan and provide any comments.





Kitsap County | ADA Transportation Facilities Transition Plan

ADA Survey Response Data Summary

1,224 Kitap County ADA Total Responses 298

1. Please tell us about yourself

Answer	Count	Percent
I have a disability	64	22%
I have no disability	217	74%
I support a person with disabilities	18	6%
I prefer not to say	13	4%
I have a disability and I support one or more persons with disability	10	3%

2. If you have a disability/condition or you support someone with a disability/condition, please check all that apply

Answer	Count	Percent
Physical, mental, or emotional condition that limits learning, memory, or concentration	44	21%
Use a wheelchair	40	20%
Blindness or serious difficulty seeing when wearing glasses	27	14%
Use assistive software technology such as a screen-reader	13	7%
Condition that substantially limits one or more physical activities such as walking, climbing stairs, reaching, lifting, or carrying	108	54%
Use hearing aids or hearing assistive devices	26	13%
Deafness or hearing difficulty	25	12%
Use a service animal	3	1%
Use mobility devices	63	32%
Other	13	7%

3. What resources do you use to find information on ADA issues? (select all that apply)

Answer	Count	Percent
Washington State Department of Social and Health Services (DSHS)	15	5%
Washington State Department of Services for the Blind (DSB)	15	5%
Kitap County	67	23%
Transit Service	48	16%
Department of Veterans Affairs	23	8%
Other (e.g. the County has limited resources, I have to go elsewhere)	26	9%
Accessibility.gov		
Others		
•Travel experience		
•Medical doctor		
•Online resources		
•Staff directed learning		
•ADA		
•WCAG		
•ANSI guidelines for buildings (existing and new construction)		
•Clear path		
•CVT & Audiologist		
•Myra Dornik at Olympic Workforce Development Council		
•Kitap County Workforce		
•Websites for specific businesses and services		

4. Please show your 5-digit zip code

Answer	City	County	Count
98110	Everett	King	6
98112	Everett	King	14
98113	Everett	King	24
98114	Everett	King	12
98142	Indanola	King	2
98146	Kingston	King	19
98153	Manchester	King	1
98159	Clula	King	3
98166	Port Orchard	King	0
98187	Port Orchard	King	16
98170	Phoebe	King	21
98302	Shawano	King	17
98304	Snohomish	King	5

5. Why do you travel within unincorporated Kitap County? i.e., those areas outside of Everett or City of Poubo boundaries.

Answer	Count	Percent
Visit friends and family	134	45%
Medical appointments	124	42%
Work in unincorporated Kitap County	37	12%
Shopping	127	43%
Attend School/college	12	4%
Other community or social services	66	22%
Recreation / recreational activities	127	43%
Other	10	3%

6. How often do you travel in Kitap?

Answer	Count	Percent
Every day or more	114	38%
2-4 days per week	63	21%
1-2 days per week	16	5%
Less than weekly	8	3%

7. How do you travel within unincorporated Kitap County?

Answer	Count	Percent
Drive and park	102	34%
Walk with a service animal	5	2%
Take transit or paratransit	42	14%
Walk	92	31%
Wheelchair	25	8%
Blas/ceptor	78	26%
Walk with any type of assistance, i.e., assistance from a person, walker, cane, etc.	55	18%
Other	13	4%

8. If you use transit, how often do you use it in a typical week?

Answer	Count	Percent
Every other days per week	20	7%
2-4 days per week	15	5%
1 day per week	11	4%
Less than weekly	81	27%

9. If you walk, how far are you willing/ able to walk to your destination?

Answer	Count	Percent
Less than 1/2 mile	85	28%
1/2 - just under 1 mile	66	22%
1 mile - just under 2 miles	17	6%
2 miles or more	23	8%

10. Are you near or have you been in the past, unable to attend and participate in an event due to accessibility in unincorporated Kitap County?

Answer	Count	Percent
Yes	102	34%
No	93	31%

11. Which of the following physical barriers are/ were reasons you are not/ were not able to participate in events or access services in unincorporated Kitap County?

Answer	Count	Percent
Sidewalk barriers	34	11%
No sidewalks	64	21%
Curbs ramp/ curb barriers	39	13%
Pedestrian crosswalk issues	37	12%
Pedestrian signal issues including access to push buttons	21	7%
ADA parking not available	49	16%
Other	37	12%

12. What areas would be your first priority in improving pedestrian facilities?

Answer	Count	1st Priority Point Value
Government buildings that provide human services (e.g. City Hall, libraries, etc.)	29	87
Hospitals and other medical facilities	60	180
County parks	19	57
Community services (e.g. food banks)	10	30
Schools and institutions	12	36
Transit facilities (e.g. bus stops)	36	108
Retail services (e.g. shops, restaurants, grocery stores)	31	93
Other	26	78

13. What areas would be your second priority in improving pedestrian facilities?

Answer	Count	2nd Priority Point Value
Government buildings that provide human services (e.g. City Hall, libraries, etc.)	25	75
Hospitals and other medical facilities	29	87
County parks	25	75
Community services (e.g. food banks)	15	45
Schools and institutions	22	66
Transit facilities (e.g. bus stops)	24	72
Retail services (e.g. shops, restaurants, grocery stores)	41	123
Other	8	24

Question 14: Please list up to three locations where you have experienced (or noticed) mobility challenges, accessibility challenges, trip hazards, etc. in the City of Kitsap*.

*For these open-ended questions, please provide the location/s where you have experienced challenges with pedestrian facilities as well as a description of the problem/s you encountered.

For example:

Location: 1st Avenue, to the east of A Street

Description: Sidewalk is raised creating a trip hazard

Location	Description of Barrier
Beach Drive by Retsil veterans home	No sidewalk or shoulder
Kitsap Physical Therapy	Lack of automatic door
The Mall	Lack of automatic doors at some entrances
Downtown Poulsbo	Narrow, uneven sidewalks and curb ramp issues
S. National Avenue, north of Loxy Egan Boulevard	Lack of sidewalk and transit access routes
9989 Silverdale Way	No curb ramps
Anderson Hill Bangor train underpass	No sidewalk and safety issues using the shoulder for walking
1720 SE Mile Hill Drive parking lot of Kitsap Physical Therapy, Goodwill, Grocery Outlet	Parking lot surface pitted and uneven
Viking Avenue	No sidewalks, lack of transit service on weekends and evenings
Clear Creek Road and Vinland Terrace NW	No sidewalks; bus stop at Clear Creek & Vinland Terrace taken out of service
Sidewalks on Winslow Way, Bainbridge Island	Sandwich boards and merchandise racks on the sidewalk pose obstructions to sidewalk access with a wheelchair or mobility scooter
Marcus Whitman Middle School Port Orchard	Bathrooms are not handicap accessible
Kingston	Lack of sidewalk connectivity
Throughout Kitsap county	Lack of sidewalks
Around/near Crazy Eric's Drive-in, Bremerton	No sidewalk on restaurant side of street, gravel and debris creating trip/fall hazard
Courthouse	AD parking stalls are too far from entrance and snow removal activities utilize ADA stalls for snow storage
Fred Meyer on SR 303	Bus stop accessibility/ bus stop location on a hill
Kingston Main Street and SR 104, and west Kingston Rd	Crosswalk leads to a landscape planting bed, no sidewalk, curb, or ADA ramp
Ilahee	No sidewalks
Klahowya School upper parking lot	Poor lighting; curb issues
Port Orchard Bay and Fredrick Avenue	Crosswalk flashing lights have not worked for the last 2 years
Tremont and Lund Streets	Surface uneven, pitted with many cracks, too few bus stops, not enough of east to west and west to east bus routes, length of transit trips
A Quiet Place Park access from Kingston's urban village along Ohio Avenue NE	Washed out gravel shoulder
Between Riddell Road and NE McWilliams Road	No sidewalks along Pine Road NE
Downtown Poulsbo	Sidewalk slopes
DMV on Silverdale Way	Lack of ADA parking and access route to main entry through the parking lot has an uneven and broken surface



Kitsap County Courthouse	Bathroom accessibility issues and lack of ADA parking
Bremerton Senior Center	Located on a hill, lack of ADA parking
Ilahee Road to Bremerton	No walkable shoulder and no sidewalk
Rocky Point Road	No walkable shoulder and no sidewalk
704 Chester Avenue in front of the Frank Chop building	Uneven sidewalks
Sylvan Way	No sidewalks
SR 104 and Banister Street in Kingston	Pedestrian crossing interval is too short and button is unreliable
Silverdale Library	ADA stalls are far from entrance, no curb ramps, book drop across the street, no crosswalks are marked in the lot, lot aisles are narrow
Downtown Bremerton	Broken and uneven sidewalks
McWilliams Safeway parking lot	ADA stalls nearest to entry replaced by EV stalls
Car drop off at Bainbridge Ferry terminal	Curbs are difficult to navigate from a car
Downtown Port Orchard	Sidewalk blockage
Mitchell Avenue	No sidewalk
Old Frontier before new roundabout	No sidewalk or pedestrian lighting
Tracyton Boulevard	Lacks sidewalks
Unincorporated Kitsap County	Limited transit
Sherman Hill Road west of Viking Way	Lack of sidewalk and transit access routes
SE Mile Hill Drive and Whittier Avenue in Port Orchard	Sidewalks lacking curb ramps, connectivity and receiving ramps
Silverdale Library	Lack of curb ramps and ADA parking is a long distance from entry
Perry Avenue	Overgrown vegetation along sidewalks
Poulsbo DMV	Entry door insufficient width to allow wheelchair access
Bremerton High School	Sidewalks lack pedestrian lighting, cracked and uneven surface, high curb at crosswalk
Sons of Norway	No elevator
Jackson Avenue near Mile Hill Drive intersection in Port Orchard	Sidewalk ends at top of hill
Port Orchard Food Bank	No Sidewalk
Parkwood East Ballfield across from Fairview Middle School	Sidewalk surface uneven and difficult to navigate in a wheelchair
Downtown Kingston	Narrow, uneven sidewalks
Intersection of Arsenal Way and S Marion Street	Sidewalk and crosswalks do not meet, visibility and safety issues
1125 Bethel Avenue	Post Office doors difficult to open, not automatic
Poulsbo city limits on Viking Way	Sidewalk and bike lane ends at city limits
Many streets on Bainbridge Island	Sidewalks obstructed with untrimmed vegetation, mailboxes and other hazards
Heritage Park	Pathway too uneven for mobility scooter or wheelchair
SR 104 Kingston	Lacks sidewalks in many locations
Klahowya School	Gym bleachers need stair to accommodate unsteady walkers
From Lund Street north on Bethell Road SE and north on Mitchell Road SE	No sidewalks, surface uneven, 'pot' holes, cracks, few bus stops, not enough of east to west and west to east bus routes
Kitsap Memorial Park	Hazardous sloped access by wheelchair to the beach
Kitsap County municipal building	Problematic for wheelchair users
Bremerton Farmers Market	Mud
Olney Avenue, Port Orchard	Sidewalks along this road are typically overgrown with thorny plants, and are impossible to go around without entering the road
Senior center in Poulsbo	Narrow doorway; no automatic door opener
Phinney Bay Road	Narrow shoulder, no sidewalks and fast-moving traffic



Port Gamble Forest, Heritage Park	Parking lots consist of loose gravel or heavy compacted rock that are hazardous for those with mobility challenges. Talk of accessible trails has been nothing but talk. Parking lots typically lack dedicated handicap parking leading to potential blocking of vehicle access. Point-No-Point now has a lengthy walk to get to the park, and no Disability beach access to transition across loose sand
Silverdale	Not enough disability parking in Costco parking lot
All event venues, Kitsap Fairgrounds	Not enough ADA parking, ADA parking too far away from events
Trailheads (state and county)	Very limited access for those with limited mobility
Dickey Road	No sidewalks
Transportation across county lines	Many specialty medical services are in Pierce and King County. Transportation to these counties is limited.
Viking Way and Sherman Hill Road bus stop	There is no safe crossing location on Viking Way to access the bus stop from the opposite side of the road
Franz outlet	Small parking area, sidewalk is hard to get up to and small hard to get to the door and door is hard to open
Bethel Road SE and Bay Street, Port Orchard	Incomplete side walk construction and missing ramps
Oral Surgeon's office Mitchell Road SE Port Orchard	No ADA parking, steep ramp
Sidewalks on Schley Boulevard, Callahan Drive, and Sheridan Road.	On Schley - overgrown vegetation, sidewalk uplift (more than an inch), cracked and crumbling sidewalk. Callahan - cracked and crumbling sidewalk. On both side of the hill on East Sheridan Rd (the top intersects with Olympus/Schley) cracked and crumbling sidewalk and overgrown vegetation
Front Street Retail	Stairs between stores
Silverdale Way	Parked cars blocking shoulder access
Blue postal drop boxes or similar boxes	Inaccessible height for wheelchair users
Mall	Changing rooms are too small to accommodate wheelchair user or assistant
S National Street between McCall Boulevard W and Charleston Beach Road W	No sidewalk
Port Orchard main library- Sydney Avenue	Pavement cracks, ADA parking issues, high curbs
Winslow Way west of Madison Avenue, Parfitt Way SW, Wyatt Way- and other locations	Sidewalks abruptly end, with no sidewalks on the other side of the street. Complete lack of sidewalks on many residential streets (e.g., Grow Ave.
East on Sedgewick Street, continued up the hill past Fred Meyer shopping center	Not enough of bus stops, no sidewalks, surface uneven, cracks, not enough of east to west and west to east bus routes
Silverdale	Driveway transition and intersections that do not have traversable ramp transitions or no ramps at all
Clear Creek Trail	There are some uneven or sloped or graveled areas
Mile Hill Drive sidewalks	Crack and unsafe conditions going both ways
Keyport Saltwater Park asphalt path	Tree roots creating pathway upheaval need maintenance
Silverdale	Winco lacking sufficient quantity of ADA parking stalls
Bethel Road, Sedgwick to Lund Avenue	Lacking complete sidewalks, crosswalks and ramps
Spirit Ridge Neighborhood	No sidewalks
Point No Point Lighthouse	Lack of ADA access and ADA parking
North Beach, Kingston	No description given
City/County websites	No closed captioning



Tracyton Boulevard, north end straightaway	No sidewalk, minimal shoulders with open ditches on both sides of road
All of the roundabouts in Port Orchard	No signals to stop traffic for blind pedestrians
Downtown Poulsbo	Sidewalks have irregular surfaces
Seabeck Highway	No lighting or sidewalks
Sidewalks on Bucklin Hill between Silverdale Way and Anderson Hill Road	Sidewalk slope excessively steep, uneven surface and overgrown with weeds
Silverdale Retail Shops ie Mall, Target, Walgreens, WinCo	Sidewalk issues: slope and surface, not enough ADA parking Private property issues with insides of stores
11th Street on Manette	Construction
Soccer/Ball Parks at Marcus Whitman Middle School	Rough unpaved parking and no paved path to fields
Bethel Road at SE Lund Avenue	Sidewalks only at corners
Kingston	Sidewalk connectivity gaps
The area on Old Clifton between the Ridge 1 and the Roundabout to McCormick Trails/Villages.	There are no sidewalks between these communities
105 Anoka Avenue Bremerton WA 98337	SW corner of Anoka & Gregory has a sidewalk that is extremely uneven
South Kingston Road	No sidewalk
Current Dental on NE McWilliams Road	No ADA parking in front lot
5789 Tracyton Boulevard NW	Need ADA improvements to provide community access to Tracyton (Post Office, School, etc.)
Park & Recreation areas	Lack of wheelchair areas for parking, restrooms, access areas (travel surfaces) as well as bench areas for resting
Port Orchard	Bus stop route
St Michaels Hospital	Not enough handicap parking close to buildings
Sidewalks outside of downtown Kingston	General compliance issues
County roads	Lack sidewalks
Bainbridge	No bike lanes
Saltwater Park in Keyport	Path is uneven and cracked from tree roots
Strip mall 3995 Bethel Rd SE, Port Orchard, WA 98366	Access to sidewalks for someone in a wheelchair is very difficult Places like Indianola have no sidewalks to safely travel, especially when visibility outside is poor.
Rural areas with no sidewalks	
SR 104 at the entrance to Grocery Outlet in Kingston	Sidewalk gaps
Colchester from Mile Hill Drive all the way down to Hemlock Street	No sidewalks, limited paved shoulder
Townsquare Mall	Sidewalk gaps: just grass and a driveway on the Mall side of Mile High Road
NW Bucklin Hill Road uphill sidewalk to library	Sidewalk buckled and broken, sometimes overgrown, no handrails, limited passing space on sidewalk
Kingston	Sidewalk gaps
SR 303 in the Fairgrounds area	Lack of wheelchair accessible paving to access transit
Pine Road NE and NE Riddell Road	Ponding at bus stop, crosswalk not accessible, curb barrier
SR 104/Iowa Avenue NE in Kingston	Crosswalk headed west from the Filling Station to youth center leads into a flower bed
Mile Hill Drive and Whittier Avenue SE, all the way to Manchester on California Avenue SE and adjacent streets	Lack of sidewalk facility, roadway safety issues



Bremerton ferry terminal	No clear ADA drop off and pickup zone for cabs, Uber, caretaker, personal - travelers with mobility needs and aids still have to walk to street and find a way to get to anyone driving them to and from destinations
Outside of downtown Kingston	Lack of sidewalk
Levin Road, Silverdale	Sidewalk gaps
Clear Creek Road and Vinland Terrace NW	Bus service change, no longer stops at location
Suquamish	No sidewalks between Tribal Center and Old Man Park
County parks	Inconsistent quality of sidewalks/parking lots/ ingress egress access
Mitchell Road SE in Port Orchard	Lack of sidewalks
Southworth ferry terminal to Harper Church ferry parking lot	Lack of sidewalk, lighting, and ADA parking
Most of Port Orchard	Gravel shoulders, lack of sidewalk, infrequent transit access (>1mi), steep terrain, lack of street lighting
WA state ferry system	Signage is terrible or unavailable. Although there is accommodation for parking close to the bathroom on the ferry, there is no information accessible for general public to know that and there is no support for walking on the ferry. In Kingston, there is no elevator or motorized support vehicles for people with mobility issues to walk on the ferry.
Tracyton Boulevard near Bucklin Hill Road	No description
Kitsap County Fair Grounds	No sidewalks and uneven terrain
Bay Street Port Orchard	Safety measures not accessible: Orange flags to cross the street n' work well for people in wheelchairs or people pushing a wheelchair. No free hands to carry the flag.
McWilliams Road	No sidewalk
Downtown Poulsbo	Not enough ADA parking close to shops
Holly Road	No sidewalk or walkway, no street lights
The Trails Silverdale	Steep terrain and lack of sidewalk or paved access
Bremerton Downtown	City sidewalks have uneven levels, sidewalk ramps are too steep, large cracks swallow the front scooter wheels, available parking is limited
Sidewalks from Manette to 6th Street Clinic	Sidewalks from Manette bridge to 6th St clinic are steep and tree rooted
North Mason High School	Portable toilets not accessible
Bethel at Beach Drive	No sidewalks on Bethel or Beach Drive
Side streets throughout Kitsap	No sidewalks or enough room on the road shoulder to walk
1625 Gregory Way	Sidewalk has lifted up due to tree root
Miller Bay Road	No sidewalks
Costco Silverdale	Insufficient ADA parking
131 NW 73rd Street	Vehicles parked in sidewalk
Bremerton	Salvation Army area has major pot holes
SR 307 and SR 104	No transit stops
Poulsbo	Safety issues from increased volume
Kitsap Mall	Restricted/limited access to some of the larger retail stores
Ferry terminals when ramps and elevators have problems	There are times with public transit, especially ferries, that the elevators or ramps are not available for a time. Alternate routes need to be clearly indicated
Lindvog Road	Sidewalk gaps
Mile Hill Drive from the top of the hill by McDonalds all the way down to the SE	Lack of sidewalk



Lund Avenue intersection and then after the intersection going down to the High School	
Mitchell Avenue, South of the Food Bank all the way to Bethel intersection	Lack of sidewalk
Randall Way and road up to Vintage Apartments	No Slow Caution Wheelchair Area signs, no sheltered seating, no pedestrian comfort amenities
SR 104	Paved shoulder only for walking
Bank of America in Silverdale	side
Downtown Kingston neighborhoods	Lack of sidewalk and gaps in existing network
Horstman from Olney to Baby Dolly	Soft shoulder, overgrown with weeds, lack of safe walkway
Bremerton ferry terminal to fast ferry	Lack of ramps and/or wheelchair lifts
SR 307 and SR 104	There is no bus stop for passengers
Kingston	Lack of adequate ADA parking at Farmers Market
Kingston	No sidewalks in many residential areas
Erlands Point Road between Chico Road	No description
Kingston High School	Some ADA parking spots are located away from curb cuts
Seabeck, Holly Road	No lighting or walkways
Silverdale Way sidewalks	Uneven surface, narrow width
All sidewalks in south Manette	Uneven surface, narrow width, difficult for mobility cart use
1701 4th Street, Bremerton, WA 98337, at the NW corner of the alley on High Avenue between 4th Street and Burwell	Utility pole restricting sidewalk clear space width
240 NE Fairgrounds Road	Uneven/sloped/unpaved shoulders that are extremely difficult for even non-disability persons. County should update their road maintenance policy to consider minimum standards for pedestrians using the shoulder.
Gamble Bay Way and SR 104	Safety issues
SR 3	Capacity/ traffic congestion
Intercity connections (non-existent)	No wheelchair or walking route for safe travel between Indianola and Suquamish
Downtown Kingston	Uneven sidewalk approaching intersection past the Filling Station
Beach Drive	Lack of dedicated bike/walking lane and safety concerns
Olney Avenue, North of the park, South to the park, North to the Albertson's shopping center or to downtown	No sidewalks
Bucklin Hill; road that connects with Greave	Sections with no sidewalks and limited space to walk between sidewalks and guardrails
Roadways in North Kitsap	Lack of pedestrian facilities, safety concerns
Ohio Avenue NE going up the hill	Sidewalk gaps
Mile Hill Jackson/Olney	Capacity issues, limited sidewalk space, roadway safety issues
Gamble Bay Way and SR 104	No bus stop
Warren Avenue and 16th Street	Push button location issues
Wheaton Way and Sylvan Way	Push button location issues
Northbound Wheaton Way at Callahan Drive	No curb ramps to access sidewalks



Appendix E: Planning Cost Estimate



Planning Level Cost Estimate

PROJECT NAME: Kitsap County ADA Transition Plan
 JOB NUMBER: 1.22438

NOTE: This cost estimate is planning level in nature. It should be considered preliminary and for planning purposes only. It specifically excludes structural impacts to buildings and parking structures, inflation, and sales tax. Potential items such as retaining walls, earthwork, etc., are assumed to be included in the planning level estimate contingency unless otherwise indicated.

When features require multiple improvements, the cost of the smaller component is included in the larger task. (e.g. detectable warning surface is included with curb ramp reconstruction.)

ROW Facilities

Item No.	ADA Deficiency	Improvement Type	Quantity	Unit	Unit Price	Total Price
Sidewalk Improvements						
1	Non-compliant sidewalk (width, condition, slope, etc.)	Reconstruct existing sidewalk/paved shoulder walkway	189,672	SY	\$ 145	\$ 27,502,410
2	Non-compliant driveway (slope, grade break, etc.)	New driveway with sidewalk	1,637	EA	\$ 2,900	\$ 4,747,300
Subtotal						\$ 32,249,710
Maintenance/Miscellaneous						
3	Non-compliant vertical discontinuity (>1/4in - <=1/2in w/out bevel)	Sidewalk grinding (5 LF of sidewalk)	2,803	LF	\$ 250	\$ 700,750
4	Non-compliant vertical discontinuity (>1/2in)	Replace two adjacent sidewalk panels (5ft x 5ft panels)	1,444	EA	\$ 806	\$ 1,163,222
5	Non-compliant horizontal discontinuity	Sidewalk crack sealing/grouting (5LF per occurrence)	23,960	LF	\$ 5	\$ 119,800
6	Fixed obstacles	Relocation of obstacles including utility pole, mailbox, tree trunk, etc.	397	EA	\$ 3,000	\$ 1,191,000
7	Moveable obstacles	Relocation of obstacles including tree/bush (prunable), message boards, parked cars, etc.	1,838	EA	\$ 200	\$ 367,600
8	Protruding obstacles	Relocation of obstacles including of bush/tree, signs, awnings etc.	841	EA	\$ 500	\$ 420,500
Subtotal						\$ 3,962,872
Curb Ramp Improvements						
9	Missing curb ramps	Install new curb ramp	453	EA	\$ 6,000	\$ 2,718,000
10	Non-compliant ramp (running slope, cross slope, ramp width, flare slope, lip, grade break, etc.)	Remove and reconstruct existing ramp	1,866	EA	\$ 6,000	\$ 11,196,000
11	Curb ramps without detectable warning surface (DWS), non-compliant DWS placement, non-compliant DWS depth, or non-compliant DWS width	Install/replace detectable warning surface	90	EA	\$ 1,030	\$ 92,700
12	Curb ramp at marked crosswalk does not end within crosswalk	Rechannelize crosswalk	7	EA	\$ 1,100	\$ 7,700
Subtotal						\$ 14,014,400
Pushbutton Improvements						
13	Non-APS push button and push button is located incorrectly	Install new APS push button AND Install new pole	196	EA	\$ 5,900	\$ 1,156,400
15	APS push button that has non-compliant dimensions and/or programming and located incorrectly	Reprogram push button, reorient push button, and/or install tactile arrow AND Install new pole and relocate push button	40	EA	\$ 3,700	\$ 148,000
17	APS push button located incorrectly	Install new pole and relocate push button	15	EA	\$ 3,500	\$ 52,500
16	APS push button that has non-compliant dimensions and/or programming	Reprogram push button, reorient push button, and/or install tactile arrow	70	EA	\$ 200	\$ 14,000
Subtotal						\$ 1,370,900
Total						\$ 51,598,000
Contingency @ 20%						\$ 10,319,600
Design @ 12%						\$ 6,191,760
Mobilization @ 8%						\$ 4,127,840
TESC + Traffic Control @ 12%						\$ 6,191,760
Construction Management @ 20%						\$ 10,319,600
Right-of-Way @ 20%						\$ 10,319,600
Total	Grand Total 2024 Dollars					\$ 99,068,000

Planning Level Cost Estimate - Right-of-Way

PROJECT NAME: Kitsap ADA Transition Plan
 TG PROJECT NUMBER: 1.22438



NOTE: This cost estimate is planning level in nature. It should be considered preliminary and for planning purposes only. It specifically excludes right-of-way acquisition and all associated costs, structural impacts to buildings and parking structures, and sales tax. Potential items such as retaining walls, earthwork, etc., are assumed to be included in the planning level estimate contingency unless otherwise indicated.

This planning cost estimate covers only the pedestrian features within the first stage of data collection.

Quantity by Priority

Feature	Low		Medium		High		Very High		Total
	1-15 (0-10 hazards)	%	16-30 (11-20 hazards)	%	31-45 (21-30 hazards)	%	46+ (31+ hazards)	%	
Sidewalks (SY)	15,232	8%	94,304	50%	76,379	40%	3,757	2%	189,672
Driveways (EA)	669	41%	659	40%	286	17%	23	1%	1,637
Non-compliant vertical discontinuity (EA)	1,566	37%	1,926	45%	707	17%	48	1%	4,247
Non-compliant horizontal discontinuity (LF)	7,660	32%	11,390	48%	4,555	19%	355	1%	23,960
Fixed obstacles (EA)	63	16%	178	45%	140	35%	16	4%	397
Moveable obstacles (EA)	553	30%	866	47%	397	22%	22	1%	1,838
Protruding obstacles (EA)	259	31%	418	50%	148	18%	16	2%	841
Curb ramps (EA)	92	4%	457	19%	1,021	42%	845	35%	2,415
Push buttons (EA)	10	3%	93	30%	178	58%	26	8%	307

Cost by Priority

Feature	Low		Medium		High		Very High		Total
	1-15 (0-10 hazards)	%	16-30 (11-20 hazards)	%	31-45 (21-30 hazards)	%	46+ (31+ hazards)	%	
Sidewalks (SY)	\$ 2,208,636	8%	\$ 13,674,067	50%	\$ 11,074,884	40%	\$ 544,823	2%	\$ 27,502,410
Driveways (EA)	\$ 1,940,100	41%	\$ 1,911,100	40%	\$ 829,400	17%	\$ 66,700	1%	\$ 4,747,300
Non-compliant vertical discontinuity (EA)	\$ 650,389	35%	\$ 874,278	47%	\$ 321,194	17%	\$ 18,111	1%	\$ 1,863,972
Non-compliant horizontal discontinuity (LF)	\$ 38,300	32%	\$ 56,950	48%	\$ 22,775	19%	\$ 1,775	1%	\$ 119,800
Fixed obstacles (EA)	\$ 189,000	16%	\$ 534,000	45%	\$ 420,000	35%	\$ 48,000	4%	\$ 1,191,000
Moveable obstacles (EA)	\$ 110,600	30%	\$ 173,200	47%	\$ 79,400	22%	\$ 4,400	1%	\$ 367,600
Protruding obstacles (EA)	\$ 129,500	31%	\$ 209,000	50%	\$ 74,000	18%	\$ 8,000	2%	\$ 420,500
Curb ramps (EA)	\$ 373,080	3%	\$ 2,455,260	18%	\$ 6,116,060	44%	\$ 5,070,000	36%	\$ 14,014,400
Push buttons (EA)	\$ 12,100	1%	\$ 261,300	19%	\$ 943,500	69%	\$ 151,200	11%	\$ 1,368,100

	Low 1-15	Medium 16-30	High 31-45	Very High 46+	Total
Total	\$ 5,652,000	\$ 20,150,000	\$ 19,882,000	\$ 5,914,000	\$ 51,596,000
Contingency @ 20%	\$ 1,130,400	\$ 4,030,000	\$ 3,976,400	\$ 1,182,800	\$ 10,319,200
Design @ 12%	\$ 678,240	\$ 2,418,000	\$ 2,385,840	\$ 709,680	\$ 6,191,520
Mobilization @ 8%	\$ 452,160	\$ 1,612,000	\$ 1,590,560	\$ 473,120	\$ 4,127,680
TESC + Traffic Control @ 12%	\$ 678,240	\$ 2,418,000	\$ 2,385,840	\$ 709,680	\$ 6,191,520
Const. Management @ 20%	\$ 1,130,400	\$ 4,030,000	\$ 3,976,400	\$ 1,182,800	\$ 10,319,200
Right-of-Way @ 20%	\$ 1,130,400	\$ 4,030,000	\$ 3,976,400	\$ 1,182,800	\$ 10,319,200
Grand Total	\$ 10,852,000	\$ 38,688,000	\$ 38,173,000	\$ 11,355,000	\$ 99,065,000



Planning Level Cost Estimate

PROJECT NAME: Kitsap County ADA Transition Plan
 JOB NUMBER: 1.22438

NOTE: This cost estimate is planning level in nature. It should be considered preliminary and for planning purposes only. It specifically excludes structural impacts to buildings and parking structures, inflation, and sales tax. Potential items such as retaining walls, earthwork, etc., are assumed to be included in the planning level estimate contingency unless otherwise indicated.

When features require multiple improvements, the cost of the smaller component is included in the larger task. (e.g. detectable warning surface is included with curb ramp reconstruction.)

On Site Facilities

Item No.	ADA Deficiency	Improvement Type	Quantity	Unit	Unit Price	Total Price
Sidewalk Improvements						
1	Non-compliant sidewalk (width, condition,	Reconstruct existing sidewalk/paved	133	SY	\$ 145	\$ 19,253
						Subtotal \$ 19,253
Maintenance/Miscellaneous						
2	Non-compliant vertical discontinuity (>1/4in - <=1/2in w/out bevel)	Sidewalk grinding (5 LF of sidewalk)	4	EA	\$ 250	\$ 1,000
3	Non-compliant vertical discontinuity (>1/2in)	Replace two adjacent sidewalk panels (5ft x 5ft panels)	1	EA	\$ 806	\$ 806
4	Non-compliant horizontal discontinuity	Sidewalk crack sealing/grouting (5LF per occurrence)	25	LF	\$ 5	\$ 125
6	Moveable obstacles	Relocation of obstacles including tree/bush (prunable), message boards, parked cars, etc.	3	EA	\$ 200	\$ 600
						Subtotal \$ 2,531
Curb Ramp Improvements						
7	Missing curb ramps	Install new curb ramp	1	EA	\$ 6,000	\$ 6,000
						Subtotal \$ 6,000
						Total \$ 28,000
						Contingency @ 20% \$ 5,600
						Design @ 12% \$ 3,360
						Mobilization @ 8% \$ 2,240
						Construction Management @ 20% \$ 5,600
Total						Grand Total 2024 Dollars \$ 45,000

Planning Level Cost Estimate - On-Site

PROJECT NAME: Kitsap ADA Transition Plan
 TG PROJECT NUMBER: 1.22438



NOTE: This cost estimate is planning level in nature. It should be considered preliminary and for planning purposes only. It specifically excludes right-of-way acquisition and all associated costs, structural impacts to buildings and parking structures, and sales tax. Potential items such as retaining walls, earthwork, etc., are assumed to be included in the planning level estimate contingency unless otherwise indicated.

This planning cost estimate covers only the pedestrian features within the first stage of data collection.

Quantity by Priority

Feature	Low		Medium		High		Very High		Total
	1-15 (0-10 hazards)	%	16-30 (11-20 hazards)	%	31-45 (21-30 hazards)	%	46+ (31+ hazards)	%	
Sidewalks (SY)	0	0%	76	58%	56	42%	0	0%	133
Non-compliant vertical discontinuity (EA)	0	0%	5	100%	0	0%	0	0%	5
Non-compliant horizontal discontinuity (LF)	0	0%	25	100%	0	0%	0	0%	25
Moveable obstacles (EA)	0	0%	3	100%	0	0%	0	0%	3

Cost by Priority

Feature	Low		Medium		High		Very High		Total
	1-15 (0-10 hazards)	%	16-30 (11-20 hazards)	%	31-45 (21-30 hazards)	%	46+ (31+ hazards)	%	
Sidewalks (SY)	\$ -	0%	\$ 11,084	58%	\$ 8,169	42%	\$ -	0%	\$ 19,253
Non-compliant vertical discontinuity (EA)	\$ -	0%	\$ 1,806	100%	\$ -	0%	\$ -	0%	\$ 1,806
Non-compliant horizontal discontinuity (LF)	\$ -	0%	\$ 125	100%	\$ -	0%	\$ -	0%	\$ 125
Moveable obstacles (EA)	\$ -	0%	\$ 600	100%	\$ -	0%	\$ -	0%	\$ 600

	Low 1-15	Medium 16-30	High 31-45	Very High 46+	Total
Total	\$ -	\$ 14,000	\$ 9,000	\$ -	\$ 22,000
Contingency @ 20%	\$ -	\$ 2,800	\$ 1,800	\$ -	\$ 4,400
Design @ 12%	\$ -	\$ 1,680	\$ 1,080	\$ -	\$ 2,640
Mobilization @ 8%	\$ -	\$ 1,120	\$ 720	\$ -	\$ 1,760
Const. Management @ 20%	\$ -	\$ 2,800	\$ 1,800	\$ -	\$ 4,400
Grand Total	\$ -	\$ 22,000	\$ 14,000	\$ -	\$ 36,000

Appendix F: Accessible Pedestrian Signal (APS) Policy Example

Kitsap County - Policy for Installation of Accessible Pedestrian Signals and Push Buttons

Intent:

It is Kitsap County's intention to be consistent with the most current version of the Public Right of Way Access Guidelines (PROWAG) in the provision and location of accessible pedestrian signals and push buttons (APS) at traffic signals. Further guidance is available in 28 CFR Part 35 and Manual on Uniform Traffic Control Devices (MUTCD) section 4E.08 through 4E.13.

Purpose:

The purpose of this plan is to establish a reasonable and consistent policy for installing APS.

Scope:

1. *Requests*: Requests for APS systems from the public will be responded to in a timely manner, and the consideration for installation will be done in accordance with applicable sections of the ADA.
2. *New construction*: New construction of traffic signal projects requires installation of APS and associated accessible features when pedestrian signals are installed.
3. *Curb ramp replacement at traffic signals*: Altering or replacing curb ramps does not require installation of APS unless the curb ramp cannot be altered or replaced without the alteration, installation, or replacement of any pole to which a pedestrian push button is attached. Then, installation of APS on poles in accessible locations is required.
4. In addition to the above conditions, APS will be installed through fulfillment of the County's obligations to complete its ADA Transition Plan.

Installation of APS is not required, unless otherwise noted, under the following conditions but is recommended when inclusion in the project scope is possible:

1. *Minor work and routine maintenance at traffic signals*: Projects including, but not limited to, emergency repairs, vehicular detection installation and repairs, installation and repair of CCTV or other cameras. Vehicular signal head upgrades and repairs, and repair of pedestrian detection do not require installation of APS and associated accessible features.
2. *Signal timing changes*: Updating signal timing, including cycle length, splits, offsets, and pedestrian clearance times do not require installation of APS and associated accessible features.
3. *Alterations*: When the signal controller and software are altered, the pedestrian signal head is replaced, or pedestrian detectors are replaced, the existing pedestrian signals shall be upgraded to APS on poles in accessible locations.

Appendix G: Grievance Procedure Example

COMPLAINT PROCEDURE

These procedures apply to all complaints filed under Title VI of the Civil Rights Act of 1964 and the Civil Rights Restoration Act of 1987, or under Executive Order 12898 on Environmental Justice, or under any related statutes and regulations, relating to any program or activity administered by the Kitsap County Department of Public Works or its sub-recipients, consultants, and/or contractors. The Kitsap County Department of Public Works is responsible for ensuring that all Title VI discrimination complaints occurring within the Federal-aid transportation program or its activities are investigated. If a complaint is against the Department of Public Works, the Washington State Department of Transportation (WSDOT) Office of Equal Opportunity (OEO) will investigate the complaint. Intimidation or retaliation of any kind is prohibited by law.

The procedures do not deny the right of the complainant to file formal complaints with other state or federal agencies or to seek private counsel for complaints alleging discrimination. Every effort is made to resolve complaints informally at Kitsap County's Department of Public Works Road Division and subrecipient level. The option of informal mediation meetings between the affected parties and a designated mediator may be utilized for resolution.

INSTRUCTIONS TO CLAIMANTS:

Please submit your complaint within 180 calendar days of the alleged occurrence or from when the alleged discrimination became known to you.

Please use the Kitsap County Department of Public Works Title VI [Complaint Form](#) and submit it to:

Kitsap County
Department of Public Works
Attention: Title VI Coordinator
614 Division Street MS-26
Port Orchard, WA 98366

Form available via Public Works Title VI
website:
<https://www.kitsapgov.com/pw/Pages/Title-VI.aspx>
OR
Call 360-337-5777
OR
Via E-Mail kitsap1@co.kitsap.wa.us

PROCESSING OF COMPLAINTS:

1. Any individual, group of individuals, or entity that believes they have been subjected to discrimination prohibited by nondiscrimination requirements may file a written complaint with Kitsap County's Human Resources, Public Works, or Board of County Commissioners. A formal complaint must be filed within 180 calendar days of the alleged occurrence. Kitsap County's Department of Public

Works Road Division will not officially act or respond to complaints made verbally.

2. Upon receiving the written complaint, Kitsap County's Department of Public Works Road Division determines its jurisdiction, acceptability, need for additional information, and the investigative merit of the complaint. In some situations, Kitsap County's Department of Public Works Road Division may request the WSDOT Office of Equal Opportunity (OEO) conduct the investigation. In the event WSDOT handles the investigation, they will follow their adopted procedures for investigating discrimination complaints, per their current State Title VI Plan.
3. If the complaint is against a subrecipient, consultant, or contractor, under contract with Kitsap County's Department of Public Works Road Division, the appropriate division and/or agency shall be notified of the complaint, within 15 calendar days.
4. Once Kitsap County's Department of Public Works Road Division decides its course of action, the complainant and the respondent will be notified in writing of such determination within five calendar days. The complaint will be logged into the records of the Title VI Coordinator, and the basis for the allegation identified including race, color, national origin, handicap/disability, age, or sex.
5. In cases where Kitsap County's Department of Public Works Road Division assumes investigation of the complaint, Kitsap County's Department of Public Works Road Division provides the respondent with the opportunity to respond to the allegations in writing. The respondent has ten calendar days upon receipt, to furnish Kitsap County's Department of Public Works Road Division with his/her response to the allegations.
6. Within 60 days of receipt of the complaint, the Coordinator or WSDOT investigator will prepare a written investigative report for Kitsap County's Department of Public Works Road Division's Engineer and Public Works Director. The report shall include a narrative description of the incident, identification of persons interviewed, findings, and recommendations for disposition.
7. The recommendation shall be reviewed by the Prosecuting Attorney's office (PA). The PA discusses the report and recommendations with the Coordinator and other appropriate departmental staff. The report is modified as needed and made final for its release to the parties.
8. Once the investigative report becomes final, briefings are scheduled with each party within 15 days. Both the complainant and the respondent shall receive a

copy of the investigative report during the briefings and are notified of their respective appeal rights.

9. A copy of the complaint and Kitsap County's Department of Public Works Road Division's investigative report is issued to WSDOT's External Civil Rights Branch (or the appropriate oversight agency) within 60 calendar days of the receipt of the complaint.
10. If the complainant or respondent is not satisfied with the results of the investigation of the alleged discriminatory practice(s) he or she shall be advised of their rights to appeal Kitsap County's Department of Public Works Road Division's decision to WSDOT, U.S. Department of Transportation (USDOT) or U.S. Department of Justice. The complainant has 180 calendar days after the appropriate agency's final resolution to appeal to USDOT. Unless new facts not previously considered come to light, reconsideration of the final determination by the investigating agency will not be available.
11. An annual Log of Complaints must be maintained by Kitsap County's Department of Public Works Road Division. The Log of Complaints must contain the following information for each complaint filed:
 - The name and address of the person filing the complaint.
 - The date of the complaint.
 - The basis of the complaint.
 - The disposition of the complaint.
 - The status of the complaint.

Only qualified, well-trained investigators should conduct these investigations. No agency is allowed to investigate a complaint against itself.

Appendix H: Maximum Extent Feasible (MEF) Documentation Template

Maximum Extent Feasible (MEF) Template

Project Description

Highway/Building Parameters

- Roadway Classification:
- Design Speed/Posted Speed:
- Design Year ADT:
- Truck Percentage:
- Access Control:
- Building Type:
- Facilities Provided in Building:

Existing Pedestrian Facilities – general description (for new construction projects include a summary of the project pedestrian study)

Pedestrian Design Standards – cover the following subjects

- Discuss the criteria that apply to the pedestrian elements on the project that will be built to the Maximum Extent Feasible
- Include reference(s) to the appropriate PROWAG/ADA section(s) and County Public Works Standards [including revision date]

Alternative(s) analysis - needed for new construction projects only

Proposal – cover the following subjects

- What features will remain that meet guidelines
- What features are being built to guidelines
- What is being built to the maximum extent feasible

Justification

- Discussion of what constraints/challenges there are to meet full design level
- See worksheet

Additional Benefits – new construction projects

Attachments

MEF Template – Public Right-of-Way Alteration Project Example

Project Description

This Alteration project will mill & fill SR “A” (from edge line to edge line) with 0.15’ HMA (Class 1/2” PG 64-22) from MP 4.03 to 4.45 and from MP 4.71 to 6.89. This project will overlay the roadway (from edge of pavement to edge of pavement) with 0.20’ HMA (Class 1/2” PG 64-22) from MP 4.45 to 4.71. There is no proposed paving on the County Roads.

Highway Parameters

- Roadway Classification: Non-NHS, U-I, Urban Principal Arterial.
- Funding Program: PI – Paving
- Posted/Design Speed: Mainline - 55/60 mph
- Average Daily Traffic: 25,000 (per Project Definition)
- Truck %: 9% (per Traffic Operations)
- Access Management Classification: Currently classified as Managed Access Class 3. On Master Plan for Modified Limited Access

Existing Pedestrian Facilities

There are five curb ramps and eight sidewalk ramps (from sidewalk to shoulder) located along SR “A” within the paving limits of this project. All five curb ramps and seven of the eight sidewalk ramps do not meet current ADA standards. One sidewalk ramp is located north of the “X” Street intersection (east side – E1, meets guidelines) at the north end of the sidewalk.

There are curb ramps and sidewalk ramps located at the four corners of the “Y” Avenue signalized intersection. Pedestrians can cross this intersection via six curb ramps and four marked crosswalks.

There are curb ramps and sidewalk ramps located at the southwest and northwest corners of the “Z” Way signalized tee intersection. Pedestrians can cross this intersection via three curb ramps and two marked crosswalks. There is one unmarked crossing on SR “A” located at the north side of this intersection. The unmarked crossing meets ADA standards, but the curb ramp located at the west side of the unmarked crossing does not meet ADA standards. This curb ramp is for the marked crosswalk on “Z” Way, is outside of our paving limits, and will not be addressed.

Pedestrian Design Standards

Curb Ramps – Landing, PROWAG 2005 R303.2.1.3

The cross slopes of a curb ramp landing shall be 2% maximum.

This also implies that the gutter slope adjacent to a curb ramp landing shall be 2% maximum.

Proposal

Curb Ramps and Ramps (from sidewalk to shoulder)

North of the “X” Street intersection (west side - W4)

This sidewalk ramp will be upgraded to meet County standards.

“Y” Avenue Intersection

Three of the four proposed curb ramps and all four proposed sidewalk ramps at the “Y” Avenue intersection meet current County standards. Proposed curb ramp “Y” Avenue SW2, located at the southwest corner, is designed to the maximum extent feasible.

Proposed curb ramp “Y” Avenue SW2 will maintain its current landing location to accommodate two crosswalks. All curb ramp elements will meet current County standards, except for the proposed gutter slope (4.4%) and landing cross slope (5.0%). These two elements will maintain the existing gutter slope >2%.

“Z” Way Intersection

The two proposed sidewalk ramps at the “Z” Way intersection meet current County standards. Proposed curb ramp “Z” Way SW2, located at the southwest corner, is designed to the maximum extent feasible.

Proposed curb ramp “Z” Way SW2 will maintain its current landing location to minimize the gutter slope and landing cross slope. All curb ramp elements will meet current County standards, except for the proposed gutter slope (7.4%) and landing cross slope (7.9%). These two elements will maintain the existing gutter slope >2%.

Justification

To construct the curb ramps to be 100% compliant would require re-profiling the existing roadway. This type of major reconstruction is not feasible in this type of Alteration project.

To construct the curb ramps while maintaining the existing profile of the roadway would require rebuilding the roadway adjacent to the proposed curb ramps. The rebuilt roadway would not eliminate the transition from the 2% cross slope of the curb ramps as it matches into the steeper cross slopes of the existing crosswalks but would simply move the transition further into the active traveled roadway. The result would be a grade change transition within the driving lane that would be undesirable.

Attachments

Vicinity Map

Spreadsheet

Curb Ramp Geometrics

Plan Sheets

Appendix I: ADA Terminology

ADA Terminology

Accessible Pedestrian Signals. A device that communicates information about pedestrian signal timing in non-visual format such as audible tones, speech messages, and/or vibrating surfaces.

Barrier. Obstacle that prevents movement or access.

Cross Slope. The slope that is perpendicular to the direction of travel (see running slope).

Curb Ramp. A short ramp cutting through a curb or built up to it.

Detectable Warning. A standardized surface feature built in or applied to walking surfaces or other elements to warn of hazards on a circulation path. Also known as “truncated domes”.

Fixed Obstacles. Obstacles in pathways that cannot be moved without significant changes to the existing infrastructure.

Grade Break. Location where a pathway’s slope changes.

Hazard. Miscellaneous barrier along a pedestrian circulation route.

Maximum Extent Feasible. The situation in which the nature of an existing building or facility makes it virtually impossible to comply fully with accessibility standards.

Moveable Obstacles. Obstacles in pathways that can be moved without significant changes to the existing infrastructure.

Pedestrian Access Route. A continuous and unobstructed path of travel provided for pedestrians with disabilities within or coinciding with a pedestrian circulation path.

Pedestrian Circulation Path. A prepared exterior or interior surface provided for pedestrian travel in the public right-of-way.

Ramp. A walking surface that has a running slope steeper than 1:20.

Running Slope. The slope that is parallel to the direction of travel (see cross slope).

Ramp Flare. Transitions the curb line to the elevation of the street.

Stakeholder. Focused group of the general public with interest in outreach efforts.

Turning Space. Area that provides maneuvering space at the top/bottom of a ramp.

